

GOODWE



User Manual

Grid-Tied PV Inverter

GT Series

75-125kW

V1.3-2025-07-23

Copyright ©GoodWe Technologies Co., Ltd., 2025. All rights reserved

No part of this manual can be reproduced or transmitted to the public platform in any form or by any means without the prior written authorization of GoodWe Technologies Co., Ltd.

Trademarks

GOODWE and other GOODWE trademarks are trademarks of GoodWe Technologies Co., Ltd. All other trademarks or registered trademarks mentioned are owned by their original owners.

Notice

The information in this user manual is subject to change due to product updates or other reasons. This manual cannot replace the product labels or the safety precautions unless otherwise specified. All descriptions in the manual are for guidance only.

CONTENT

1	About This Manual	1
1.1	Applicable Model	1
1.2	Target Audience	1
1.3	Symbol Definition	2
2	Safety Precaution	3
2.1	General Safety	3
2.2	DC Side	3
2.3	AC Side	4
2.4	Inverter Installation	4
2.5	Personnel Requirements	5
3	Product Introduction	5
3.1	Application Scenarios	5
3.2	Circuit Diagram	6
3.3	Supported Grid Types	7
3.4	Appearance	8
3.4.1	Parts	8
3.4.2	Dimensions	10
3.4.3	Indicators	10
3.5	Functionalities	11
3.6	Inverter Operation Mode	13
3.7	Nameplate	14
4	Check and Storage	15
4.1	Check Before Receiving	15
4.2	Deliverables	15
4.3	Storage	16
5	Installation	16
5.1	Installation Requirements	16
5.2	Inverter Installation	18
5.2.1	Moving the Inverter	18
5.2.2	Installing the Inverter	19
6	Electrical Connection	22
6.1	Safety Precautions	22

6.2	Connecting the PE Cable	24
6.3	Connecting the AC Output Cable	24
6.4	Connecting the PV Input Cable	27
6.5	Communication	31
6.5.1	RS485 Communication Networking	31
6.5.2	Power Limit Networking	31
6.5.3	Connecting the Communication Cable	34
6.5.4	Installing the Smart Dongle (optional)	36
7	Equipment Commissioning	37
7.1	Check Items before Power On	37
7.2	Power On	37
8	System Commissioning	38
8.1	Indicators and Button	38
8.2	Setting Inverter Parameters via LCD	39
8.2.1	LCD Menu Introduction	39
8.2.2	Inverter Parameter Introduction	41
8.3	Setting Inverter Parameters via App	42
8.3.1	Downloading the App	42
8.3.2	App Structure	43
8.3.3	Introductions to Login Page	44
8.3.4	GUI Introductions to Grid-Tied PV Inverters	45
8.3.5	App Operations for Grid-Tied PV Inverters	46
8.3.6	Settings	49
8.4	SEMS Portal App Overview	60
8.4.1	Login Page of SEMS Portal App	60
8.4.2	Home Page of SEMS Portal App	61
8.4.3	Monitoring Power Plant	62
9	Maintenance	63
9.1	Power Off the Inverter	63
9.2	Removing the Inverter	63
9.3	Disposing of the Inverter	63
9.4	Troubleshooting	64
9.5	Routine Maintenance	69
10	Technical Parameters	71
11	Term Explanation	77

1 About This Manual

This manual describes the product information, installation, electrical connection, commissioning, troubleshooting, and maintenance. Read through this manual before installing and operating the product. All the installers and users have to be familiar with the product features, functions, and safety precautions. This manual is subject to update without notice. For more product details and latest documents, visit www.en.goodwe.com.

1.1 Applicable Model

This manual applies to the listed inverters below (GT for short):



Model	Nominal Output Power	Nominal Output Voltage
GW75K-GT-LV-G10	75kW	127/220V, 3L/N/PE or 3L/PE
GW100K-GT	100kW	220/380V, 230/400V, 3L/N/PE or 3L/PE
GW110K-GT	110kW	
GW125K-GT	125kW	

1.2 Target Audience

This manual applies to trained and knowledgeable technical professionals. The technical personnel has to be familiar with the product, local standards, and electric systems.

1.3 Symbol Definition

Different levels of warning messages in this manual are defined as follows:

 DANGER
Indicates a high-level hazard that, if not avoided, will result in death or serious injury.
 WARNING
Indicates a medium-level hazard that, if not avoided, could result in death or serious injury.
 CAUTION
Indicates a low-level hazard that, if not avoided, could result in minor or moderate injury.
NOTICE
Highlight and supplement the texts. Or some skills and methods to solve product-related problems to save time.

2 Safety Precaution

Notice

The inverters are designed and tested strictly complies with related safety rules. Read and follow all the safety instructions and cautions before any operations. Improper operation might cause personal injury or property damage as the inverters are electrical equipment.

2.1 General Safety

Notice

- The information in this document is subject to change due to product updates or other reasons. This manual cannot replace the product labels or the safety precaution unless otherwise specified. All descriptions here are for guidance only.
- Before installations, read through the user manual to learn about the product and the precautions.
- All installations should be performed by trained and knowledgeable technicians who are familiar with local standards and safety regulations.
- Use insulating tools and wear personal protective equipment when operating the equipment to ensure personal safety. Wear anti-static gloves, cloths, and wrist strips when touching electron devices to protect the inverter from damage.
- Strictly follow the installation, operation, and configuration instructions in this manual. The manufacturer shall not be liable for equipment damage or personal injury if you do not follow the instructions. For more warranty details, visit :
<https://en.goodwe.com/warranty.asp>.

2.2 DC Side

DANGER

- Connect the DC cables using the delivered DC connectors and terminals. The manufacturer shall not be liable for the equipment damage if other connectors or terminals are used.
- Confirm the following information before connecting the PV string to the inverter. Otherwise, the inverter may be damaged permanently or even cause fire and cause personal and property losses. Above damage or injuries are not covered by the warranty.
 - Make sure that the positive pole of the PV string connects to the PV+ of the inverter. And the negative pole of the PV string connects to the PV- of the inverter.
 - For the models of GW100K-GT, GW110K-GT, GW125K-GT, the open circuit voltage of the PV string connected to each MPPT shall not exceed 1100V. When the input voltage is between 1000V and 1100V, the inverter enters the waiting mode. When the voltage returns to 180V-1000V, the inverter will resume normal operation.
 - For the models of GW75K-GT-LV-G10, the open circuit voltage of the PV string connected to each MPPT shall not exceed 800V.

WARNING

- Ensure the PV Module frames and the PV mounting system are securely grounded.
- Ensure the DC cables are connected tightly and securely.
- The PV modules used with the inverter must have an IEC61730 class A rating.
- Make sure that the PV strings connected to the same MPPT should contain the same number of identical PV modules.
- To maximize the power generation of the inverter, please ensure that the V_{mp} of the PV modules connected in series is within the MPPT Voltage Range at Nominal Power of the inverter; as shown in the **Technical Parameters**.
- The voltage difference between two MPPTs shall be less than 150V.
- Make sure that the input current of each MPPT does not exceed the Max. Input Current per MPPT, as shown in the **Technical Parameters**.
- When there are multiple PV strings, please connect them to as much inverter MPPTs as possible.

2.3 AC Side









WARNING

- The voltage and frequency at the connecting point should meet the on-grid requirements.
- An additional protective device like the circuit breaker or fuse is recommended on the AC side. Specification of the protective device should be at least 1.25 times the Max. output current.
- You are recommended to use copper cables as AC output cables. If you prefer aluminum cables, we remember to use copper to aluminum adapter terminals.

2.4 Inverter Installation

DANGER

- Terminals at the bottom of the inverter cannot bear much load. Otherwise, the terminals will be damaged.
- All labels and warning marks must be clear and distinct after the installation. Do not block, alter, or damage any label.
- Warning labels on the inverter are as follows.

	<p>HIGH VOLTAGE HAZARD. Disconnect all incoming power and turn off the product before working on it.</p>		<p>Delayed discharge. Wait 5 minutes after power off until the components are completely discharged.</p>
	<p>Read through the guide before working on this device.</p>		<p>Potential risks exist. Wear proper PPE before any operations.</p>
	<p>High-temperature hazard. Do not touch the product under operation to avoid being burnt.</p>		<p>Grounding point. Indicates the position for connecting the PE cable.</p>
	<p>CE marking</p>		<p>Do not dispose of the inverter as household waste. Discard the product in compliance with local laws and regulations, or send it back to the manufacturer.</p>

2.5 Personnel Requirements

NOTICE

- Personnel who install or maintain the equipment must be strictly trained, learn about safety precautions and correct operations.
- Only qualified professionals or trained personnel are allowed to install, operate, maintain, and replace the equipment or parts.

3 Product Introduction

3.1 Application Scenarios

NOTICE

The inverters are for industrial use / installation only. They are not applicable for residential or household installation.

The GT inverter is a three-phase PV string grid-tied inverter. The inverter converts the DC power generated by the PV module into AC power and feeds it into the utility grid. The intended use of the inverter is as follows:

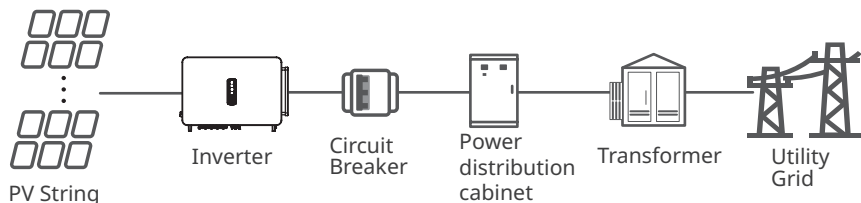

Model Description

GW75K-GT-LV-G10



No.	Referring to	Explanation
1	Brand code	GW: GoodWe
2	Nominal power	75K: the nominal power is 75kW
3	Series code	GT: GT Series
4	Grid type	LV: Low Voltage Grid
5	Version code	the inverter version is 1.0

3.2 Circuit Diagram

The circuit diagram of GW75K-GT-LV-G10/GW100K-GT is as follows.

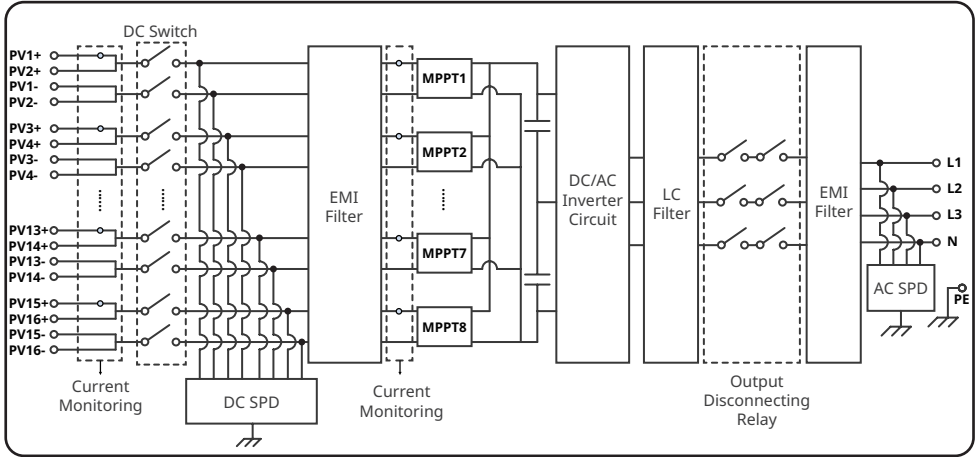

The circuit diagram of GW110K-GT/GW125K-GT is as follows.

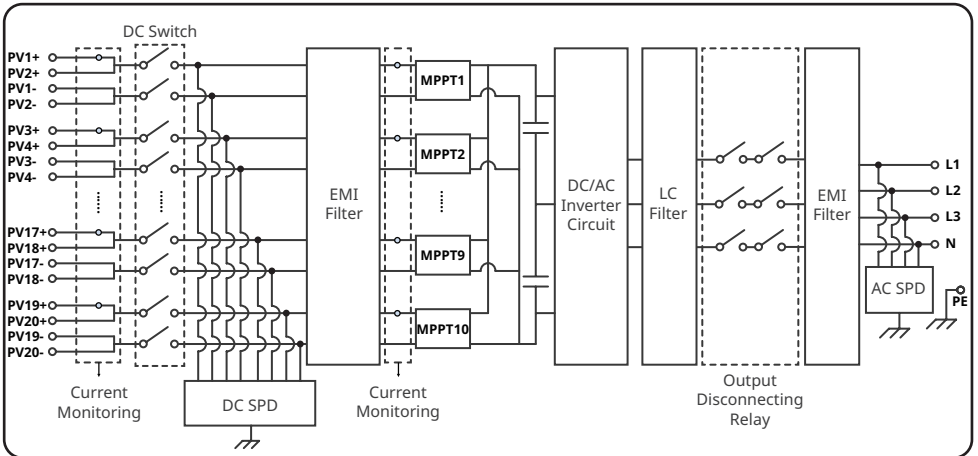

3.3 Supported Grid Types

NOTICE

For the TT grid structure, the effective value of the voltage between the neutral wire and the ground wire must be less than 20V.

The grid structures supported by GW75K-GT-LV-G10, GW100K-GT, GW110K-GT and GW125K-GT are TN-S, TN-C, TN-C-S, TT, IT, as shown in the figure below:

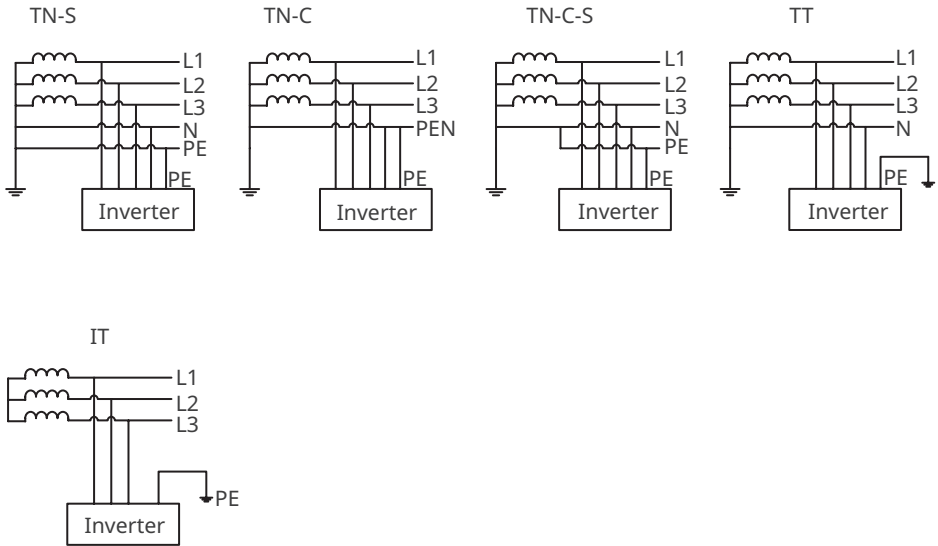

3.4 Appearance

3.4.1 Parts

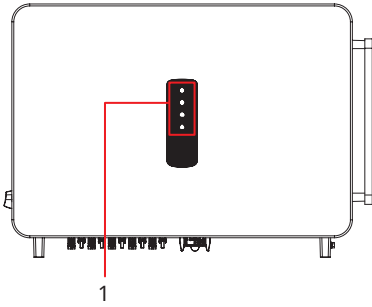

Without LCD

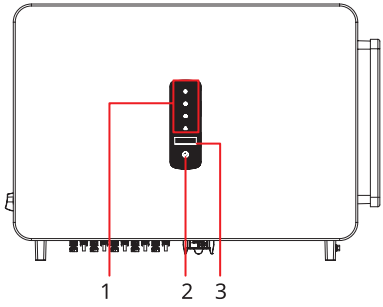

With LCD

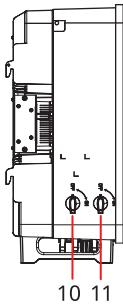
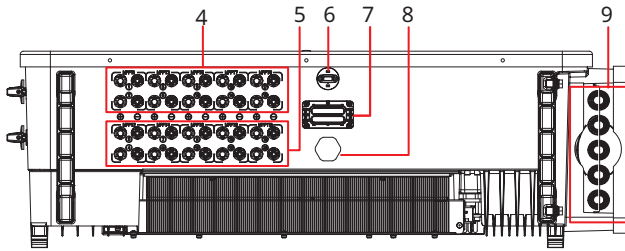





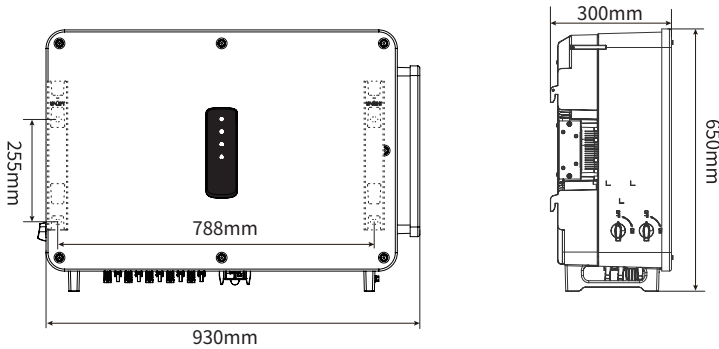













No.	Parts	Description
1	Indicator	Indicates working state of the inverter.
2	Button (optional)	To control contents displayed on the screen.
3	LCD (optional)	To check the parameters of the inverter.
4	DC Input Terminal	To connect the PV module DC input cables. GW75K-GT-LV-G10&GW100K-GT: MPPT1/3/5/7; GW110K-GT&GW125K-GT: MPPT1/3/5/7/9
5	DC Input Terminal	To connect the PV module DC input cables. GW75K-GT-LV-G10&GW100K-GT: MPPT2/4/6/8; GW110K-GT&GW125K-GT: MPPT2/4/6/8/10
6	Communication Port 1	To connect the smart dongle such as WiFi, 4G, and so on.
7	Communication Port 2	Used to connect the RS485 communication cable.
8	Ventilation valve	For waterproofing, ventilation, and to balance the internal and external air pressure.
9	AC Cable Outlet Hole	The outlet of AC cable.
10	DC Switch 2	Start or stop MPPT2/4/6/8 or MPPT2/4/6/8/10 DC input.
11	DC Switch 1	Start or stop MPPT1/3/5/7 or MPPT1/3/5/7/9 DC input.
12	Grounding Point	To connect the PE cable.

3.4.2 Dimensions



3.4.3 Indicators

Indicator	Status	Description
		ON = EQUIPMENT POWER ON
		OFF = EQUIPMENT POWER OFF
		ON = THE INVERTER IS FEEDING POWER
		OFF = THE INVERTER IS NOT FEEDING POWER
		SINGLE SLOW FLASH = SELF CHECK BEFORE CONNECTING TO THE GRID
		SINGLE FLASH = CONNECTING TO THE GRID
		ON = WIRELESS IS CONNECTED/ACTIVE
		BLINK 1 = WIRELESS SYSTEM IS RESETING
		BLINK 2 = WIRELESS ROUTER PROBLEM
		BLINK 4 = WIRELESS SERVER PROBLEM
		BLINK = RS485 IS CONNECTED
		OFF = WIRELESS IS NOT ACTIVE
		ON = A FAULT HAS OCCURRED
		OFF = NO FAULT

3.5 Functionalities

AFCI

Inverters with AFCI functionality has built-in current sensors to detect the high frequency current signals and decide whether an electric arc occurs. If there is, the inverter is able for self-protection automatically.

Reason to occur electric arcs:

- Damaged connectors in PV system.
- Wrong connected or broken cables.
- Aging connectors and cables.

Method to detect electric arcs:

- When the inverter detects an electric arc, users can check the fault via LCD or SolarGo App.
- If the electric arc fault happens less than 5 times within 24 hours, the alarm can be cleared automatically. After the 5th electric arc fault, the inverter shuts down for protection. Only after the fault is solved, the inverter can work normally. For details, refer to **SolarGo App User Manual**.

PID Recovery (Optional)

During the operation of PV panels, there is a potential difference between the output electrodes and the grounded frame of the panels. Over an extended period, this can lead to a decrease in the power generation efficiency of the panels, which is known as the Potential Induced Degradation (PID) effect.

The PID function of this unit operates by elevating the voltage differential between the PV panels and their frames to a positive value (termed as positive-voltage elevation). This effectively suppresses the PID effect and is applicable to P - type PV panels as well as N-type PV panels that necessitate positive - voltage elevation for PID suppression. For N - type PV panels that demand negative - voltage reduction to suppress the PID effect, it is advisable to deactivate this function. Regarding whether an N - type module falls into the category that requires positive - voltage elevation for PID suppression, please consult the module supplier.

Reactive power control At night (SVG, optional)

To improve the power generation performance of the power station at night, the inverter supports night SVG function. Issuing a reactive power compensation command via the power station monitoring platform, which makes the inverter keep working even when there is no active power output.

RSD (Optional)

Optionally, working with a signal transmitter inverters with RSD functionality communicate with the RSD (Module-Level Smart Controller) installed on the external of the PV strings. This allows the DC power generated by the PV string to be sustainably delivered to the inverter. In case of an emergency, turn off the AC circuit breaker at the output side of the inverter. The transmitter inside of the inverter is cut off, consequently to interrupt the current output of the PV strings.

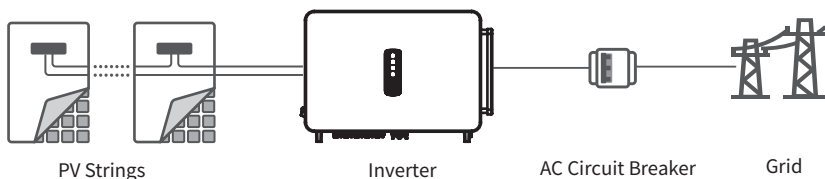

Communication

The inverter supports: parameter setting via Bluetooth; connection to the SMES monitoring platform via WiFi, 4G, or WiFi+LAN, thus monitoring the operations of the inverter and the power plant, etc. via SMES App.

- Bluetooth : meets Bluetooth 5.1 standard.
- WiFi : supports 2.4G frequency band. Set the router to 2.4G or 2.4G/5G coexistence mode. 40 bytes for router wireless signal name maximumly.
- LAN : supports connecting to the router via LAN communication, and then connecting to the monitoring platform.
- 4G : supports connected to the monitoring platform via 4G communication.

The actual communication method depends on the inverter model.

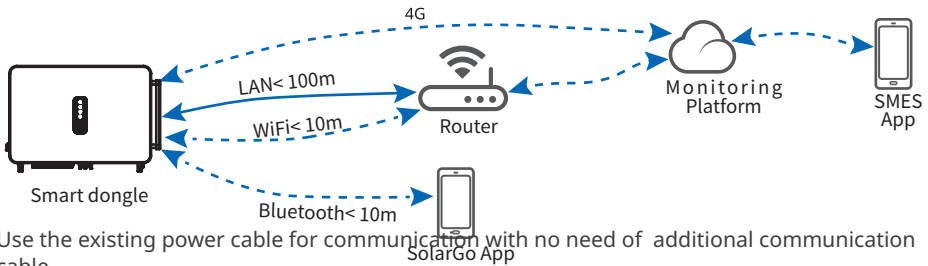

Use the existing power cable for communication with no need of additional communication cable.

PLC networking (Optional)

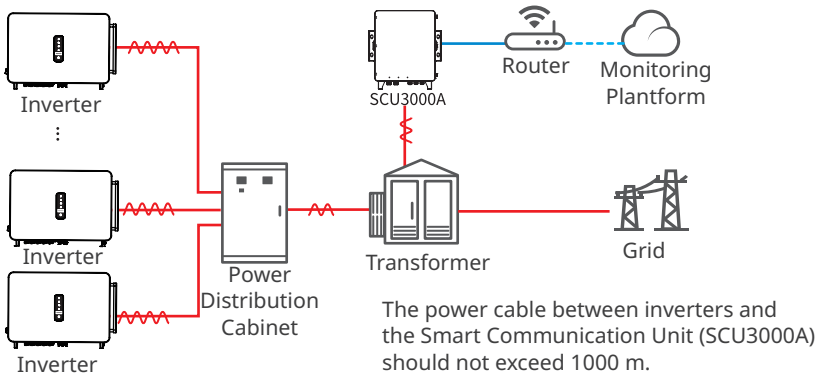

Fuse detection (Optional, and only for South Korea)

- The inverter detects if the fuse is broken. If it is, the inverter will stop the grid tied running for protection. This fault can be checked via LCD or SolarGo App.
- Only when all PV inputs of the inverter have PV strings connected, the fuse detection can be used.

3.6 Inverter Operation Mode

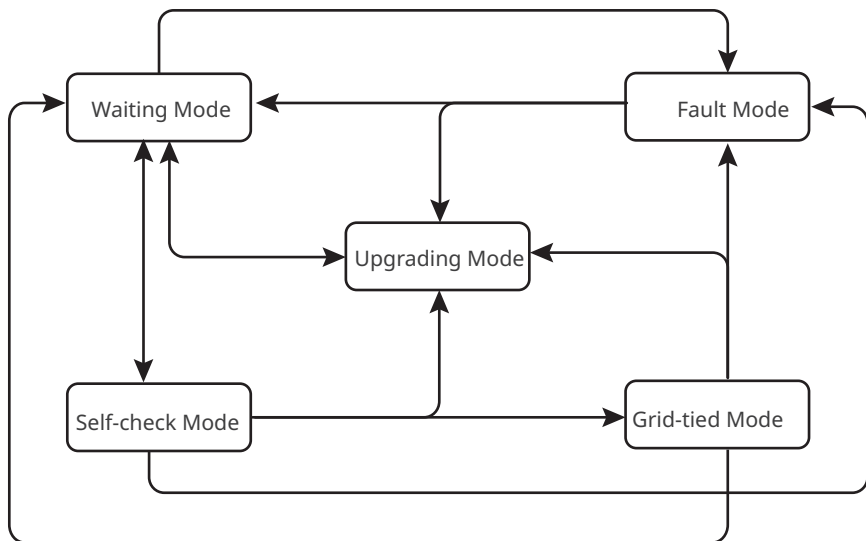

No.	Mode	Description
1	Waiting Mode	Waiting stage after the inverter is powered on. <ul style="list-style-type: none"> When the conditions are met, the inverter enters the self-check mode. If there is a fault, the inverter enters the fault mode. If received an upgrade request, the inverter enters the upgrading mode.
2	Self-check Mode	Before the inverter starts up, it continuously performs self-check, initialization, etc. <ul style="list-style-type: none"> When the conditions are met, the inverter enters the grid-tied mode, and the inverter starts on-grid connection. If received an upgrade request, the inverter enters the upgrading mode. If the self-check does not passed, it enters the fault mode.
3	Grid-tied Mode	The inverter has connected to the grid and is operating normally. <ul style="list-style-type: none"> If a fault is detected, it enters the fault mode. If received an upgrade request, the inverter enters the upgrading mode.
4	Fault Mode	If a fault is detected, the inverter enters the fault mode. When the fault is cleared, it enters the waiting mode. When the waiting mode ends, the inverter detects the running status and it enters the next mode.
5	Upgrading Mode	Inverters enter this mode when the firmware update process is initiated. After the upgrading, the inverter enters the waiting mode. When the waiting mode ends, the inverter detects the running status and it enters the next mode.

3.7 Nameplate

The nameplate is for reference only.

GOODWE		Goodwe trademark, product type, and product model
Product: Grid-Tied PV Inverter Model : *****_***_**		
PV Input	UDCmax: **** Vd.c.	Technical parameters
	UMPP: **...*** Vd.c.	
	Idc,max: ** Ad.c.	
	ISC PV: ** Ad.c.	
Output	UAC,r: *** Va.c.	
	fAC, r: ** Hz	
	PAC,r: ** kW	
	IAC,max: ** Aa.c.	
	SR: ** kVA	
	Smax: ** kVA	
P,F,: ~*,**cap.,**ind T operating: ~**~** °C Non-isolated, IP**, protective Class I, OVC DCIII/ACIII		
		Safety symbols and certification marks
S/N:		Contact information and serial number
***** Co., Ltd. E-mail: *****@***.com *****		

4 Check and Storage

4.1 Check Before Receiving

Check the following items before receiving the product.

1. Check the outer packing box for damage, such as holes, cracks, deformation, and others signs of equipment damage. Do not unpack the package and contact the supplier as soon as possible if any damage is found.
2. Check the inverter model. If the inverter model is not what you requested, do not unpack the product and contact the supplier.
3. Check the deliverables for correct model, complete contents, and intact appearance. Contact the supplier as soon as possible if any damage is found.

4.2 Deliverables

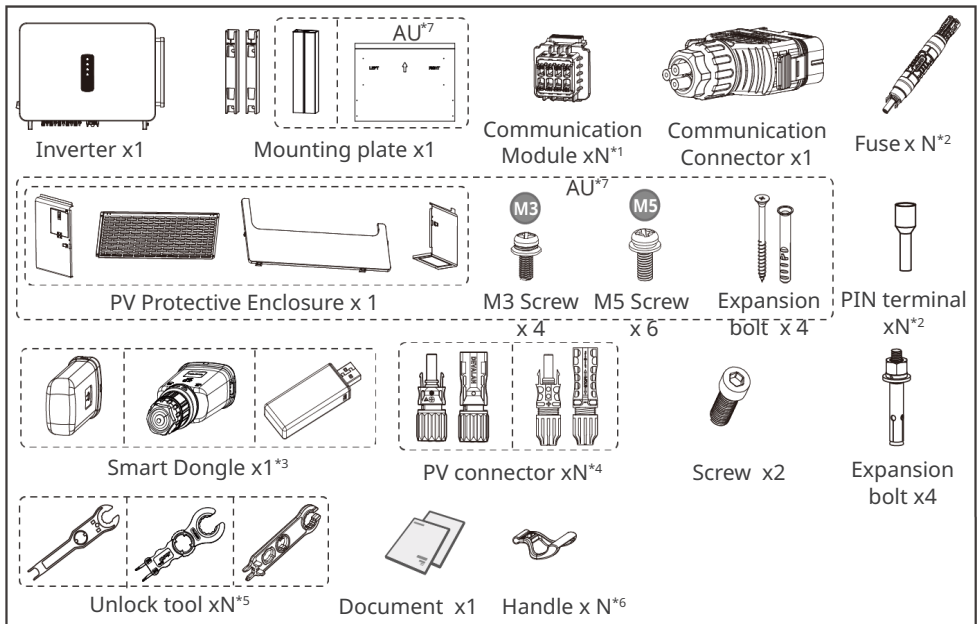

N = Quantity or type depend on the inverter model.

NOTICE

*1 Depending on the selected communication method, the number of built-in communication modules can be either 1 or 2, while the number of pin terminals is between 8 and 16 respectively.

*2 Only for South Korea and Australia.

*3 Smart dongle types are available: WiFi/4G/Bluetooth/WiFi/LAN, etc. The actual delivered type depends on the selected inverter communication method.

*4 The number of PV connectors equals with the number of the inverter's DC input terminals.

*5 For South Korea models, N is 3, and for other models, it is 2.

*6 Australia: SIB optional; Overseas: standard; China: optional but requires a separate order.

*7 Only for Australia.

4.3 Storage

If the equipment is not to be installed or used immediately, please ensure that the storage environment meets the following requirements:

1. Do not unpack the outer package or throw the desiccant away.
2. Store the equipment in a clean place. Make sure the temperature and humidity are appropriate and no condensation.
3. The height and direction of the stacking inverters should follow the instructions on the packing box.
4. The inverters must be stacked with caution to prevent them from falling.
5. If the inverter has been stored for more than two years or has not been in operation for more than six months after installation, it is recommended to be inspected and tested by professionals before being put into use.
6. To ensure good electrical performance of the internal electronic components of the inverter, it is recommended to power it on every 6 months during storage. If it has not been powered on for more than 6 months, it is recommended to be inspected and tested by professionals before being put into use.

5 Installation

5.1 Installation Requirements

Installation Environment Requirements

1. Do not install the equipment in a place near flammable, explosive, or corrosive materials.
2. Install the equipment on a surface that is solid enough to bear the inverter weight.
3. Install the equipment in a well-ventilated place to ensure good dissipation. Also, the installation space should be large enough for operations.
4. The equipment with a high ingress protection rating can be installed indoors or outdoors. The temperature and humidity at the installation site should be within the appropriate range.
5. Install the equipment in a sheltered place to avoid direct sunlight, rain, and snow. Build a sunshade if it is needed.
6. Do not install the equipment in a place that is easy to touch, especially within children's reach. High temperature exists when the equipment is working. Do not touch the surface to avoid burning.
7. Install the equipment at a height that is convenient for operation and maintenance, electrical connections, and checking indicators and labels.
8. Install the inverters far away from noise-sensitive areas, such as the residential area, school, hospital etc., in order to avoid the noises bothering people nearby.
9. Install the inverter away from high magnetic field to avoid electromagnetic interference. If there is any radio or wireless communication equipment below 30MHz near the inverter, you have to:
 - Install the inverter at least 30m far away from the wireless equipment.
 - Add a low pass EMI filter or a multi winding ferrite core to the DC input cable or AC output cable of the inverter.

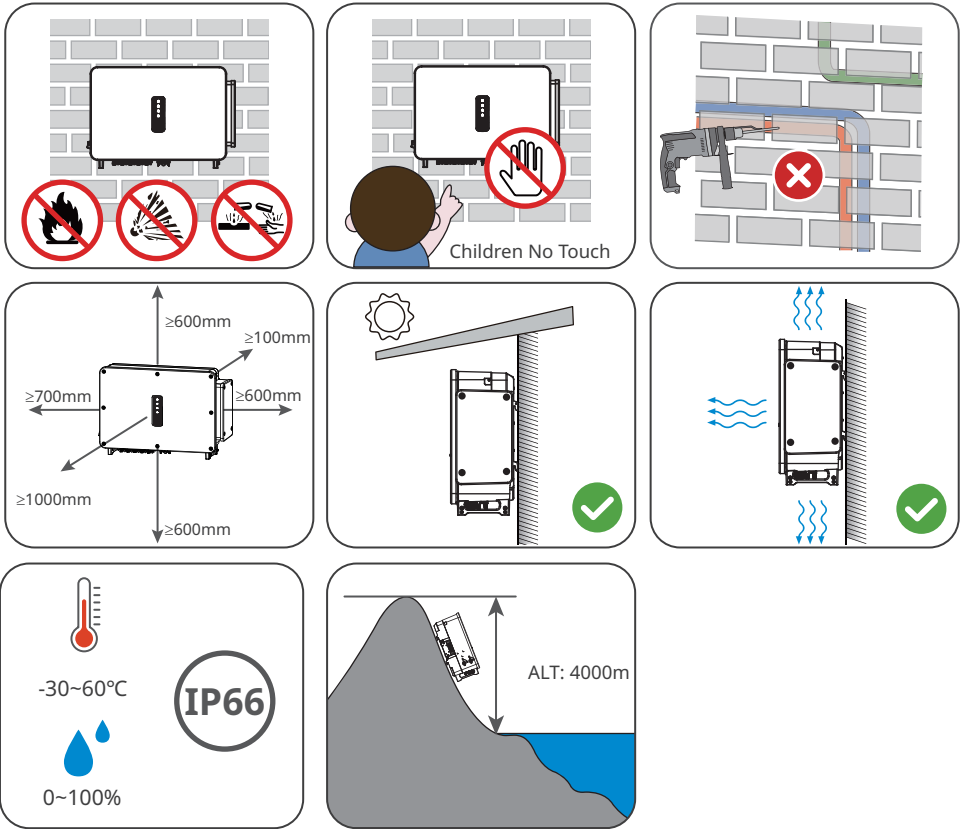

Mounting Support Requirements

- The mounting support shall be nonflammable and fireproof.
- Make sure that the support surface is solid enough to bear the product weight load.

Installation Angle Requirements

- Install the inverter vertically or at a maximum back tilt of 15 degrees.
- Do not install the inverter upside down, forward tilt, back forward tilt, or horizontally.

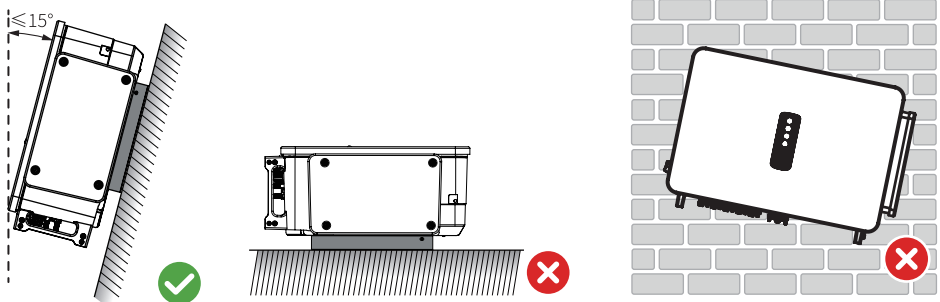

Installation Tool Requirements

The following tools are recommended when installing the equipment. Use other auxiliary tools on site if necessary.

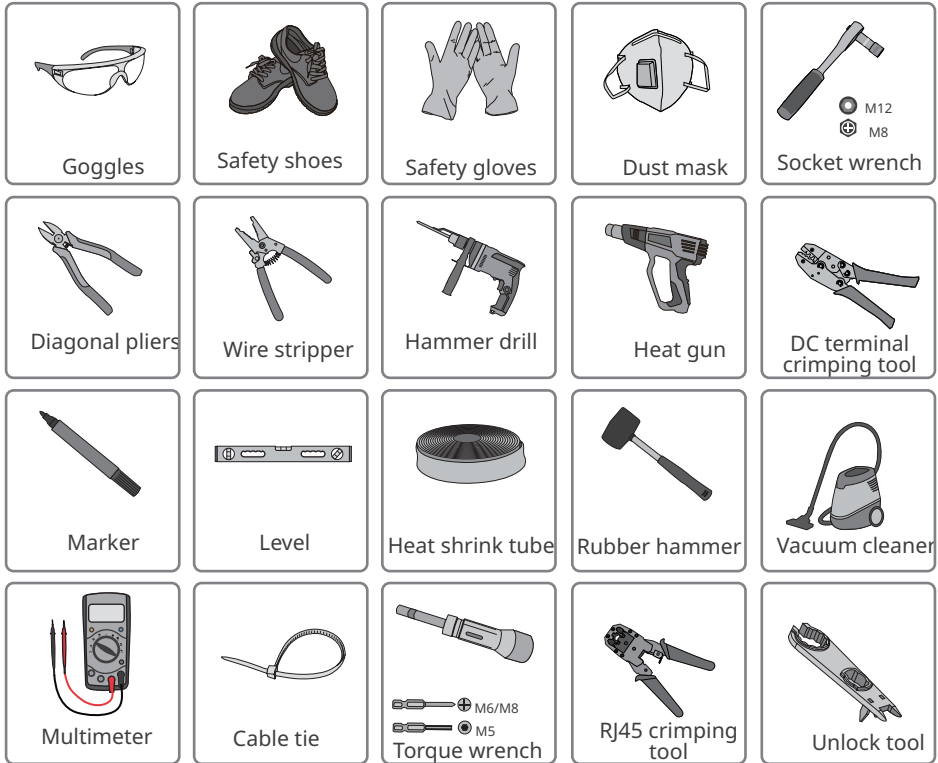

5.2 Inverter Installation

5.2.1 Moving the Inverter

 **CAUTION**

Move the inverter to the site before installation. Follow the instructions below to avoid personal injury or equipment damage.

1. Consider the weight of the equipment before moving it. Assign enough personnel to move the equipment to avoid personal injury.
2. Wear safety gloves to avoid personal injury.
3. Keep balance when moving the equipment.

5.2.2 Installing the Inverter

NOTICE

- Avoid the water pipes and cables buried in the wall when drilling holes.
- Wear goggles and a dust mask to prevent the dust from being inhaled or contacting eyes when drilling holes.

Installing the mounting plate

Step 1 Put the mounting plate on the wall horizontally, mark positions for drilling holes.

Step 2 Drill holes to a depth of 65mm (Australia:80mm) using the hammer drill. The diameter of the drill bit should be 13mm (Australia:8mm) .

Step 3 Fix the mounting plate on the wall or the bracket.

Mounting on the wall

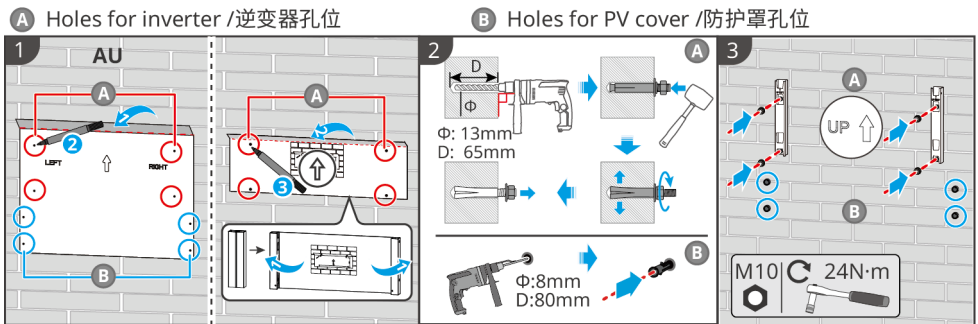

Mounting on the bracket

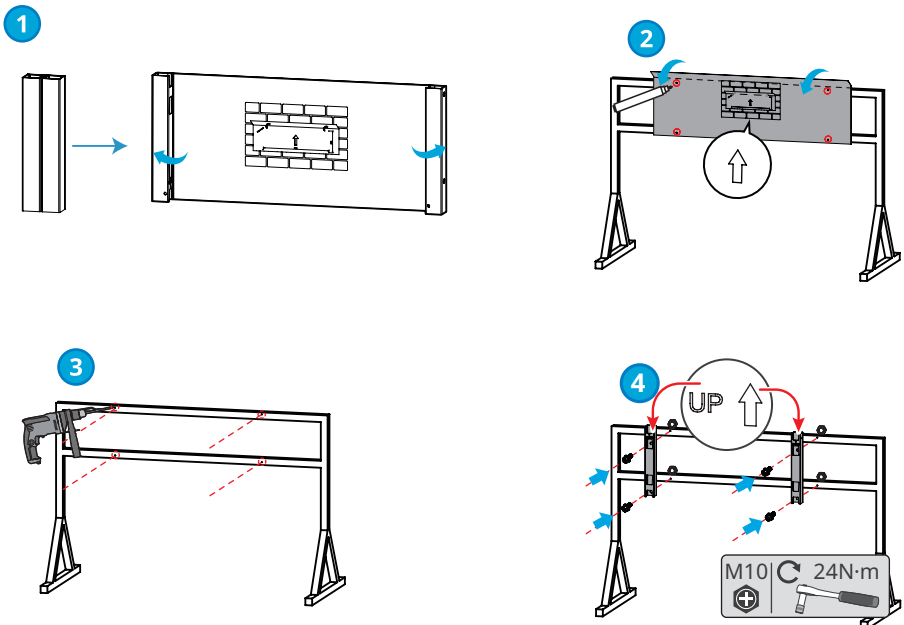

Installing the Inverter

NOTICE

- Prepare the handles or hoisting rings. Contact the dealer or the after-sales center to purchase them if needed.
- Confirm the installation of the handles or hoisting rings are secure enough to bear the weight of the inverter.

Type 1 With handles

Step 1 Install and secure the handles to the inverter.

Step 2 Grab the handles to lift the inverter, or hoist the inverter, and place it onto the mounting plate. Tighten the nuts to secure the mounting plate and the inverter.

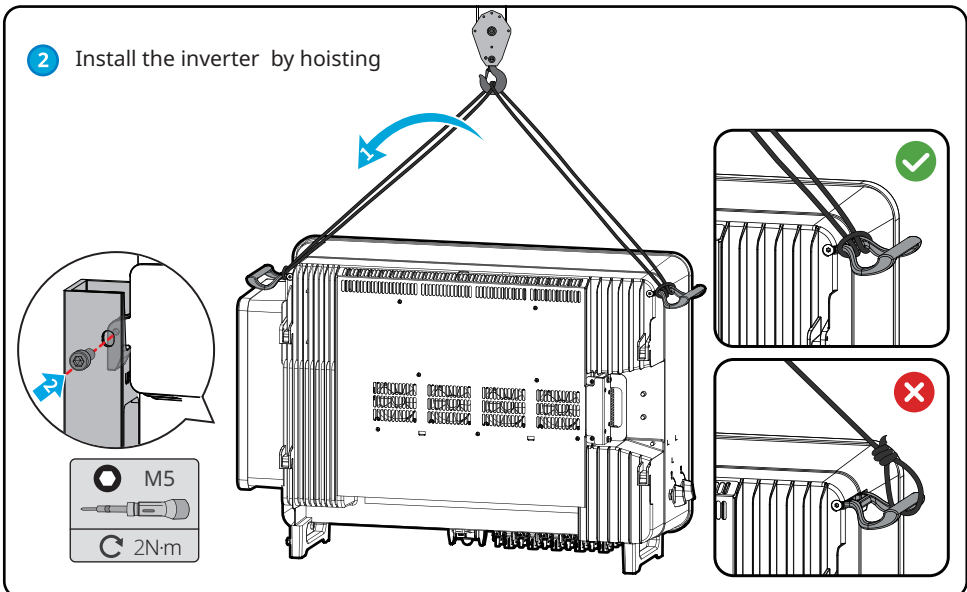
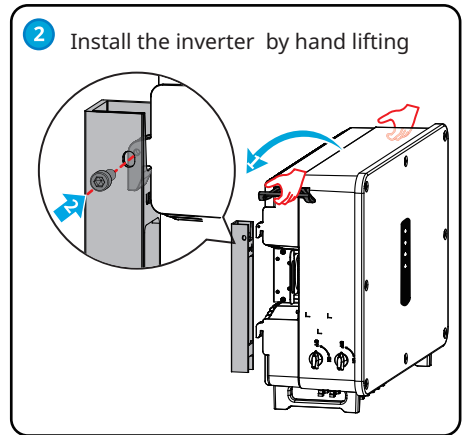
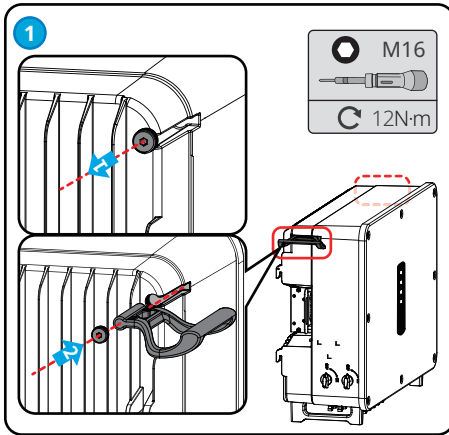

Type 2 Without handles

Step 1: Place the inverter face up and lift it horizontally by holding all four corners.

Step 2: Support the bottom of the inverter, lift it, steady it, and then mount it onto the rear bracket. Secure the bracket and inverter firmly.

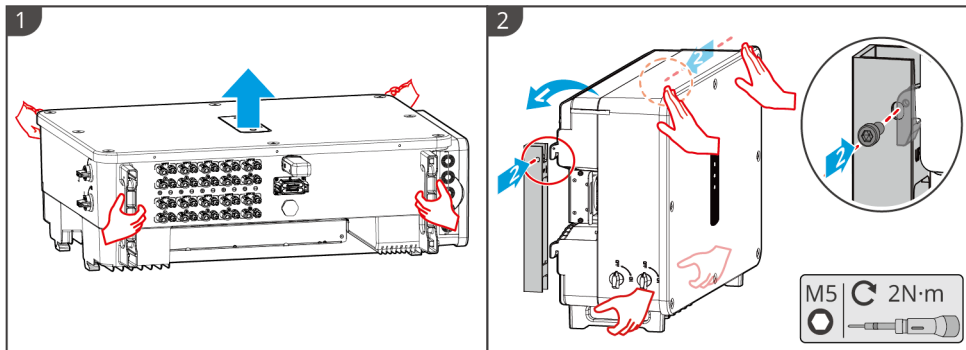

Installing the PV Protective Cover (Australia only)

Step 1: Assemble the PV cover using the correct screw and hinge specifications.

Step 2: Fix the PV cover onto the wall, ensuring it is securely installed.

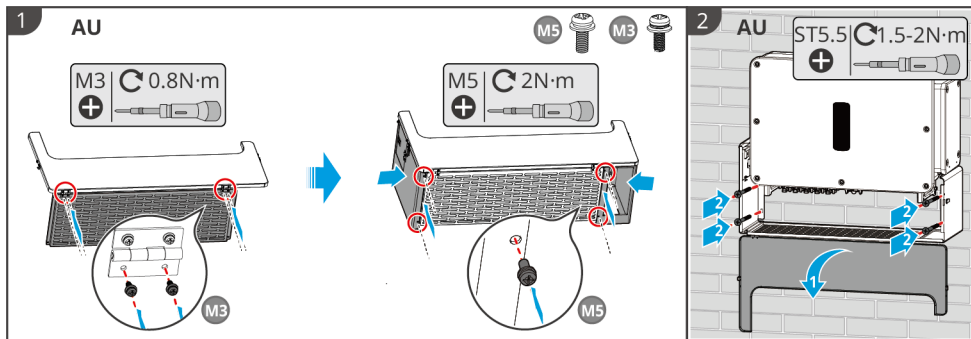

6 Electrical Connection

6.1 Safety Precautions

DANGER

- Disconnect the DC switch and the AC output switch of the inverter to power off the equipment before any electrical connections. Do not work with power on. Otherwise, an electric shock may occur.
- Perform electrical connections in compliance with local laws and regulations. Including operations, cables, and component specifications.
- If the tension is too large, the cable may be poorly connected. Reserve a certain length of the cable before connecting it to the inverter cable port.

NOTICE

- Wear personal protective equipment like safety shoes, safety gloves, and insulating gloves during electrical connections.
- All electrical connections should be performed by qualified professionals.
- Cable colors in this document are for reference only. The cable specifications should meet local laws and regulations.
- The GW100K-GT, GW110K-GT and GW125K-GT models differ only in the number of MPPTs. The wiring methods are the same. Below is taking the GW110K-GT wiring as an example.

No.	Cable	Type	Cable Specification	
			Outer Diameter (mm)	Cross-sectional Area (mm ²)
1	PE cable	Copper Outdoors cable	11 ~ 30	$S_{PE} \geq S/2^{*1}$
2	AC output cable (multi-core)	Multi-core outdoor cable	35 ~ 69	<ul style="list-style-type: none"> • Copper core : 70 ~ 240 • Aluminum alloy cable or copper-clad aluminum cable : 95 ~ 240 • PE: $S_{PE} \geq S/2^{*1}$
3	AC output cable (single core)	Single-core outdoor cable	11 ~ 30	<ul style="list-style-type: none"> • Copper core : 70 ~ 240 • Aluminum alloy cable or copper-clad aluminum cable : 95 ~ 240 • PE: $S_{PE} \geq S/2^{*1}$
4	DC input cable	PV cable that meets 1100V standard.	4.7 ~ 6.4	4 ~ 6
5	RS485 communication cable	Outdoor shielded twisted pair. The cable should meet local requirements.*2	4.5 ~ 6	0.2 ~ 0.5

Note:

*1: S_{PE} refers to the cross-sectional area of the protective earth conductor, and S refers to the cross-sectional area of the AC cable conductor.

*2: The total length of the communication cable shall not exceed 1000m.

The values in this table are valid only if the external protective earth conductor is made of the same metal as the phase conductor. Otherwise, the cross-sectional area of the external protective earthing conductor shall be such that its conductivity is equivalent to that specified in this table.

6.2 Connecting the PE Cable

WARNING

- The PE cable connected to the enclosure of the inverter cannot replace the PE cable connected to the AC output port. Both of the two PE cables must be securely connected.
- Make sure that all the grounding points on the enclosures are equipotential connected when there are multiple inverters.
- To improve the corrosion resistance of the terminal, it is recommended to apply silica gel or paint on the ground terminal after installing the PE cable.
- Prepare the PE cable according to the cable specifications and OT grounding terminals according to the following figure.
- Other sizes of grounding cables that meet local standards and safety regulations can also be used for grounding connections. But GOODWE shall not be held liable for any damage caused.

Specification of Grounding OT Terminals

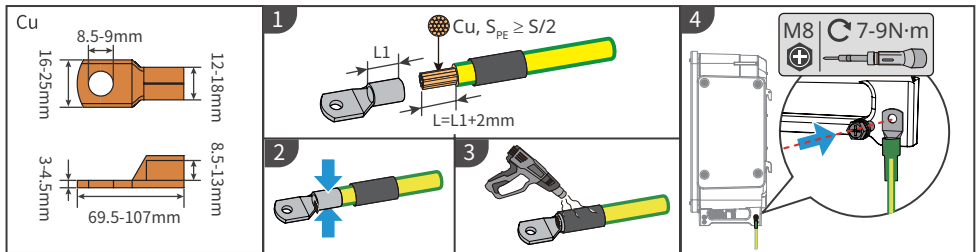

6.3 Connecting the AC Output Cable

WARNING

- Do not connect loads between the inverter and the AC switch directly connected to it.
- The Residual Current Monitoring Unit (RCMU) is integrated into the inverter. The inverter will disconnect from the utility grid rapidly once it detects any leak current over the permissible range.

Select and Install RCD depending on local laws and regulations. Type A RCDs (Residual Current Monitoring Device) can be connected to the outside of the inverter for protection when the DC component of the leakage current exceeds the limit value. The following RCDs are for reference:

Inverter model	Recommended RCD specifications
GW75K-GT-LV-G10	≥750mA
GW100K-GT	≥1000mA
GW110K-GT	≥1100mA
GW125K-GT	≥1250mA

An AC circuit breaker should be installed on the AC side to make sure that the inverter can safely disconnect the grid when an exception happens. Select the appropriate AC circuit breaker in compliance with local laws and regulations. Recommended AC circuit breakers:

Inverter model	AC circuit breaker
GW100K-GT	200A
GW110K-GT	225A
GW75K-GT-LV-G10, GW125K-GT	250A

NOTICE

Install one AC circuit breaker for each inverter. Multiple inverters cannot share one AC circuit breaker.



WARNING

- Pay attention to the silkscreens L1, L2, L3, N, PE on the AC terminal. Connect the AC cables to the corresponding terminals. The inverter may be damaged if the cables are connected inappropriately.
- Make sure that the whole cable cores are inserted into the AC terminal holes. No part of the cable core can be exposed.
- Make sure that the cables are connected securely. Otherwise, the terminal may be too hot to damage the inverter when the inverter is working.
- The AC terminals can be connected in three-phase four-wire or three-phase five-wire. The actual wiring method may be different. The figure below takes the three-phase five-wire as an example.
- Reserve certain length of PE cable. Make ensure that the PE cable is the last one to bear the stress when the AC output cable is under tension.
- The waterproof rubber ring for the AC outlet hole is delivered with the inverter, which is located in the AC wiring box of the inverter. Please select the rubber ring types according to the actual using cables' specification.
- Prepare M8 ground OT terminals and M12 AC OT terminals.
- Use the copper alluminium transferring terminals when using alluminium cable wiring.

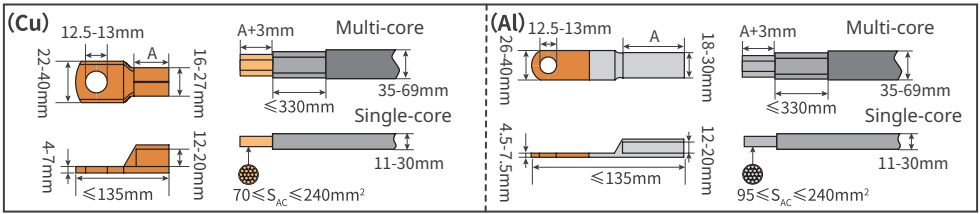

Step 1: Crimp the AC cable OT terminal, and prepare the AC output cable.

Step 2: Remove the AC terminal cover.

Step 3: Select the corresponding hole diameter according to the AC cable diameter specification, and cut off the harf-round part of the plastic pads that is located on the AC terminal cover and inverter.

Step 4: Fasten the AC output cable to the inverter.

Step 5: Tighten the AC terminal cover.

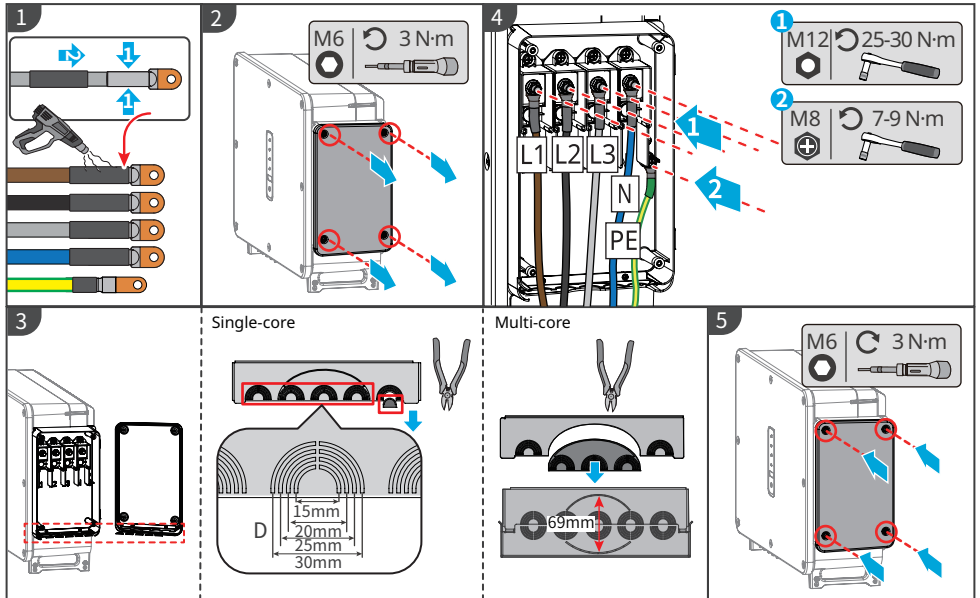

NOTICE

- Make sure that the cables are connected correctly and firmly after connections. Clean all the debris in the maintenance compartment.
- Seal the AC output terminal to ensure the Ingress Protection Rating.

6.4 Connecting the PV Input Cable

DANGER

- Do not connect the same PV string to multiple inverters, as this may cause damage to the inverter.
- Confirm the following information before connecting the PV string to the inverter. Otherwise, the inverter may be damaged permanently or even cause fire and cause personal and property losses. Above damage or injuries are not covered by the warranty.
 - Make sure that the positive pole of the PV string connects to the PV+ of the inverter. And the negative pole of the PV string connects to the PV- of the inverter.
 - For the models of GW100K-GT, GW110K-GT, GW125K-GT, the open circuit voltage of the PV string connected to each MPPT shall not exceed 1100V. When the input voltage is between 1000V and 1100V, the inverter enters the waiting mode. When the voltage returns to 180V-1000V, the inverter will resume normal operation.
 - For the models of GW75K-GT-LV-G10, the open circuit voltage of the PV string connected to each MPPT shall not exceed 800V.

WARNING

- Make sure that the PV strings connected to the same MPPT should contain the same number of identical PV modules.
- To maximize the power generation of the inverter, please ensure that the V_{mp} of the PV modules connected in series is within the MPPT Voltage Range at Nominal Power of the inverter; as shown in the **Technical Parameters**.
- The voltage difference between two MPPTs shall be less than 150V.
- Make sure that the input current of each MPPT does not exceed the Max. Input Current per MPPT, as shown in the **Technical Parameters**.
- When there are multiple PV strings, please connect them to as much inverter MPPTs as possible.

DC Input Terminal Connection Manner

GW75K-GT-LV-G10,GW100K-GT

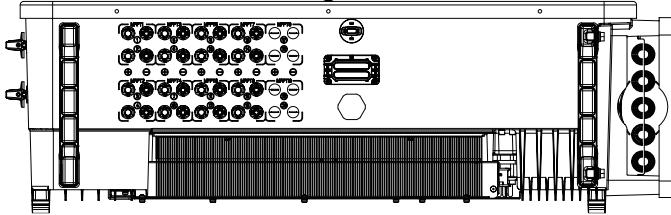

When the quantity of PV strings ≤ 8 , connect the PV strings to the inverter from MPPT1 to MPPT8 in turn.

When the quantity of PV strings >8 , please follow the table to connect the PV strings to the inverter in turn.

- : Connect 1 PV string
- : Connect 2 PV strings

Quantity of PV Strings	MPPT1	MPPT2	MPPT3	MPPT4	MPPT5	MPPT6	MPPT7	MPPT8
9	●●	●	●	●	●	●	●	●
10	●●	●●	●	●	●	●	●	●
11	●●	●	●	●	●	●●	●●	●
12	●●	●●	●	●	●●	●●	●	●
13	●●	●	●●	●●	●	●	●●	●●
14	●●	●●	●●	●●	●	●	●●	●●
15	●●	●●	●●	●●	●●	●	●●	●●
16	●●	●●	●●	●●	●●	●●	●●	●●

GW110K-GT, GW125K-GT

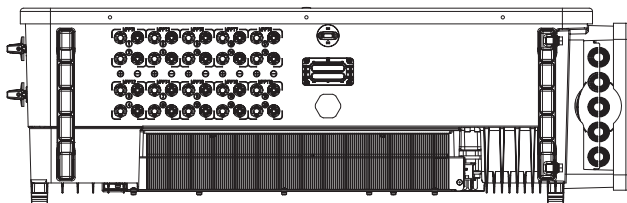

When the quantity of PV strings ≤ 10 , connect the PV strings to the inverter from MPPT1 to MPPT10 in turn.

When the quantity of PV strings >10 , please follow the table to connect the PV strings to the inverter in turn.

- : Connect 1 PV string
- : Connect 2 PV strings

Quantity of PV Strings	MPPT1	MPPT2	MPPT3	MPPT4	MPPT5	MPPT6	MPPT7	MPPT8	MPPT9	MPPT10
11	●●	●	●	●	●	●	●	●	●	●
12	●●	●	●	●	●	●	●	●	●	●●
13	●●	●	●	●	●	●●	●●	●	●	●
14	●●	●	●	●●	●	●	●●	●	●	●●
15	●●	●	●	●●	●●	●	●	●●	●●	●
16	●●	●●	●	●	●	●	●●	●●	●●	●●
17	●●	●●	●●	●	●	●	●●	●●	●●	●●
18	●●	●●	●●	●●	●	●	●●	●●	●●	●●
19	●●	●●	●●	●●	●●	●	●●	●●	●●	●●
20	●●	●●	●●	●●	●●	●●	●●	●●	●●	●●

Connecting the DC Input Cable

Step 1 Prepare DC cables.

Step 2 Crimp the DC cable with the DC PV terminals.

Step 3 Disassemble the PV connectors.

Step 4 Make the DC cable and detect the DC input voltage.

Step 5 Plug the PV connectors into the DC input terminals.

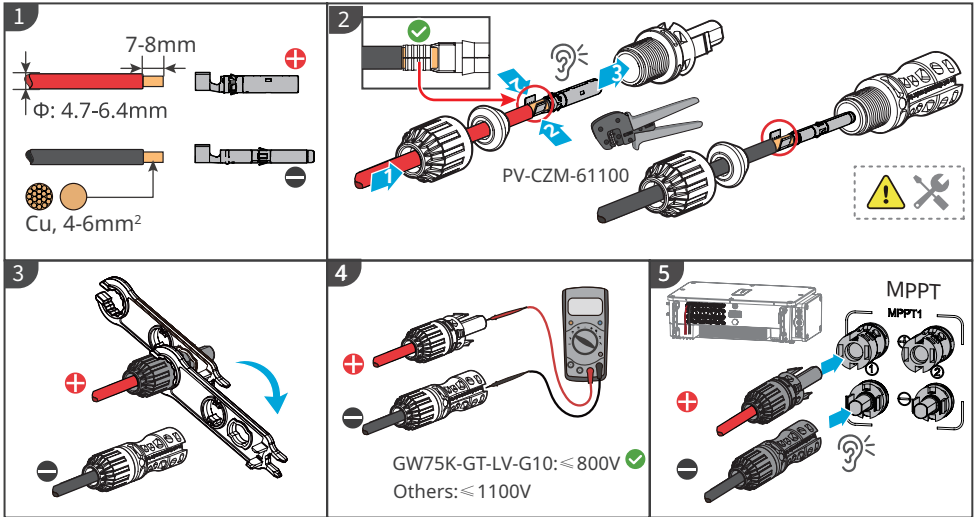

6.5 Communication

6.5.1 RS485 Communication Networking

NOTICE

- If multiple inverters are connected to the EzLogger3000C for networking, the maximum number of inverters per COM port of the EzLogger3000C is 20, and the total length of the connecting cable should not exceed 1000m.
- It is recommended to use the communication cable with shielding layer, and make it grounded during wiring.

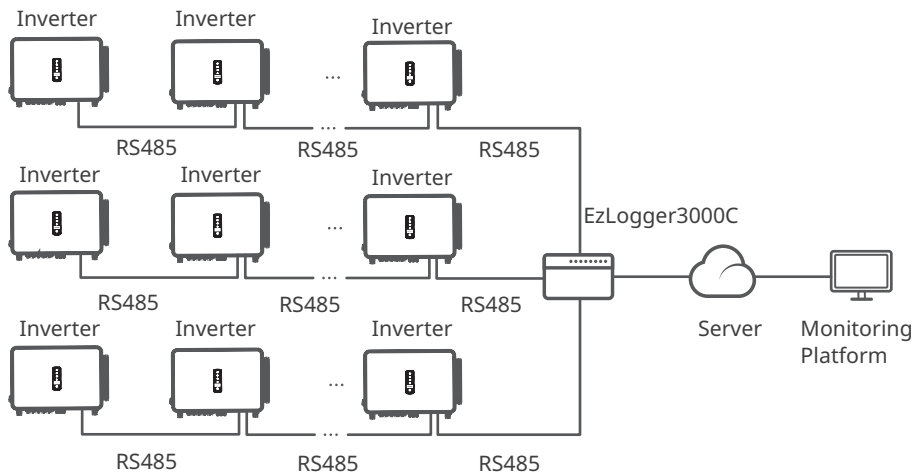

6.5.2 Power Limit Networking

When all loads in the PV system cannot consume the generated electricity, the surplus power will be fed into the grid. In this case, it is possible to monitor the power generation with a smart meter, EzLogger3000C to control the amount of power fed into the grid.

WARNING

1. The place to snap fit the CT shall be near the grid connection point and the installation direction must be right. "-->" of CT refers that the inverter current flows to the Grid. If CT is installed reversely, the inverter will be triggered with an alarm and unable to realize the power limit function.
2. The CT bore diameter shall be bigger than the outer diameter of AC power cable, to ensure the AC power cable can be inserted into CT.
3. For specific CT wirings, please refer to the documents provided by the respective manufacturer, to ensure that the wiring direction is correct and CT is able to work properly.
4. CT shall be snap fitted on Cable L1, L2 and L3. Do not install it on Cable N.
5. Specification of CT:
 - Choose nA/5A for the current transformation ratio of the CT. (nA: For primary current of the CT, n ranges from 200 to 5000. Set the current value depending on the actual needs. 5A: The output current of the secondary current of the CT.)
 - The recommended precision of the CT: 0.5, 0.5s, 0.2, 0.2s. Ensure the sampling error for the CT current shall be $\leq 1\%$.
6. To ensure the current detection accuracy of the CT, it is recommended that the length of the CT cable should not exceed 30 m and the recommended current carrying ability of the cable is 6 A .

NOTICE

1. Recommended cross-sectional area of the smart meter input power cable: 1mm²(18AWG).
2. For the three-phase three-line grid system, short circuit the N and L2 on the smart meter side and the L2 line of the grid need no CT connected.
3. Set the CT 's turns ratio via SolarGo App. For example, set the CT ratio to 40 if a 200A/5A CT is selected.
4. Scan the QR code below to get more information.



SolarGo App
User Manual

Power export limit of single inverter with GM330

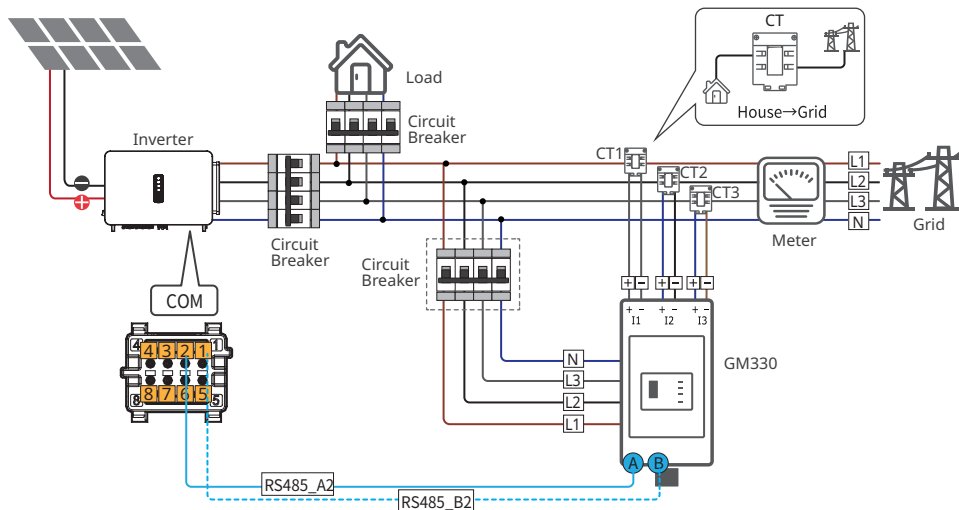

Power export limit of multi inverters with EzLogger3000C+GM330

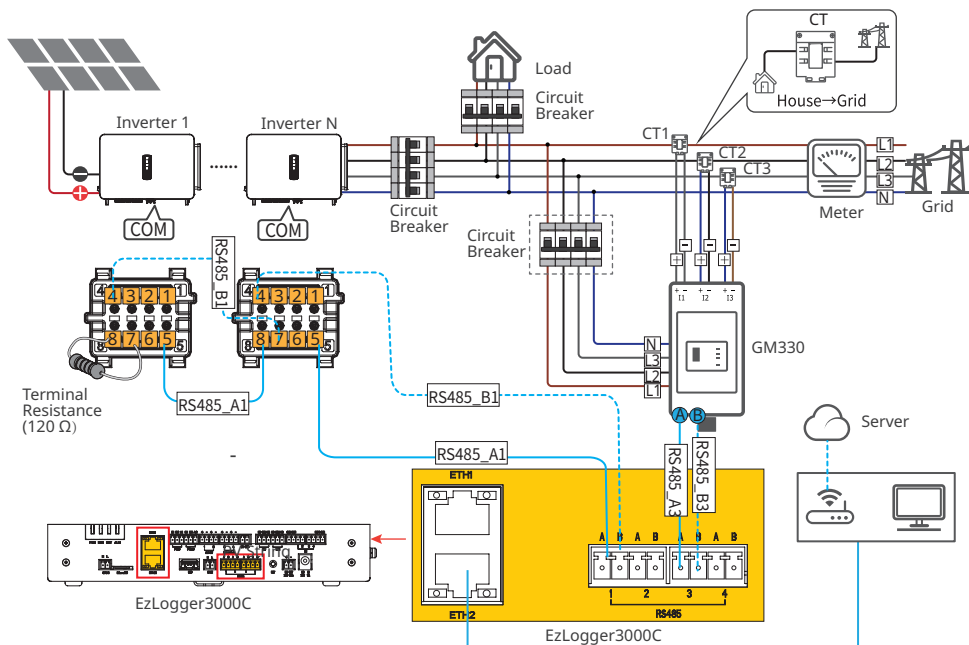

After completing the wiring, relevant parameters can be set through SolarGo App, LCD or EzLogger3000C web.

6.5.3 Connecting the Communication Cable

NOTICE

- The communication port can be configured differently according to the regulatory requirements in different regions.
- The remote shutdown function and emergency power off disabled in default. Enable it via SolarGo App if needed. Detailed steps, refer to **SolarGo App User Manual**.
- When connecting the communication line, make sure that the wiring port definition and the equipment are fully matched, and the cable alignment path should avoid interference sources, power lines, etc., so as not to affect signal reception.
- There are three wire holes in the communication terminal, corresponding to three plugs. As needed, remove the corresponding number of plugs. The unused wire holes must be plugged, to avoid affecting the protection performance of the inverter.
- Below are different configurations for certain regions.
- Only DRM 0, 5, 6, 7 and 8 were supported in the inverter.

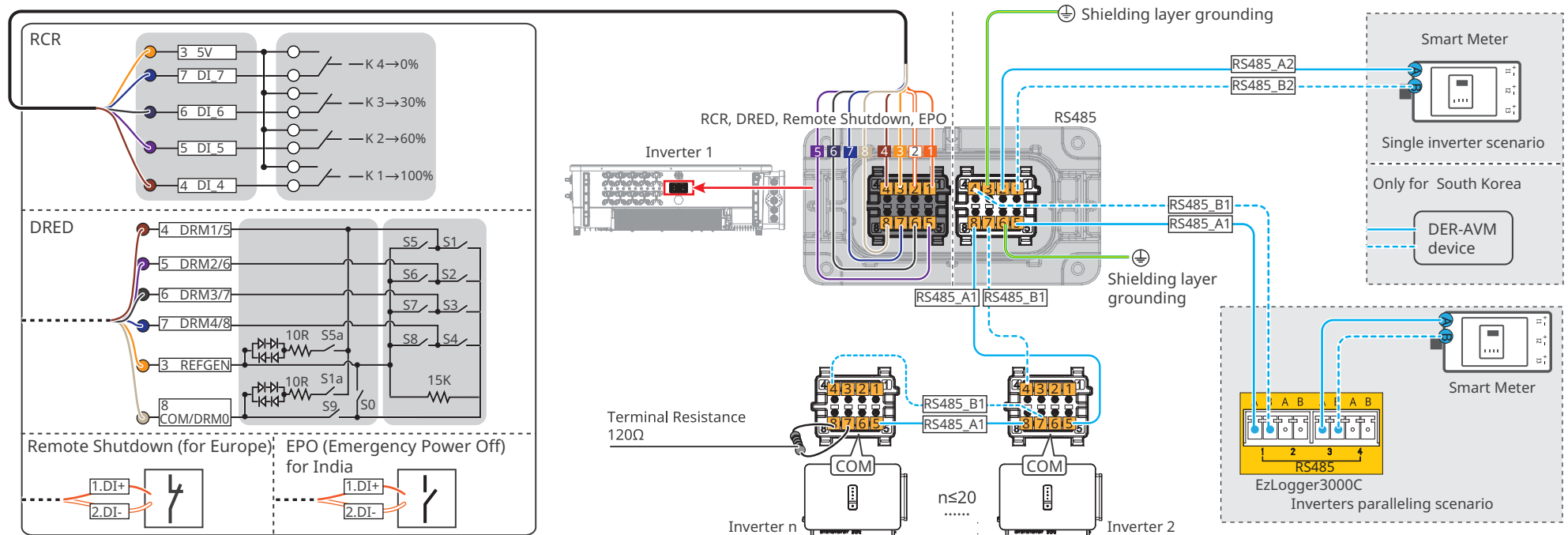

Function	No.	Definition	Description
RS485	1	RS485_B2	To connect with a smart meter.
	2	RS485_A2	
	3	Ground	To connect with multi inverters, the smart DataLogger (EzLogger3000C) or terminal resistance.
	4	RS485_B1	
	5	RS485_A1	
	6	Ground	
	7	RS485_B1	
	8	RS485_A1	
Remote Shutdown/ EPO (Emergency Poweroff)	1	DI1+	<ul style="list-style-type: none"> To connect with Remote Shutdown device (for European & Brazil models only). To connect with EPO device (for Indian models only).
	2	DI1-	
RCR	3	5V	To connect RCR device. (For European models only)
	4	DI_4(K1)	
	5	DI_5(K2)	
	6	DI_6(K3)	
	7	DI_7(K4)	
DRED	3	REFGEN	To connect DRED device. (For German models only)
	4	DRM1/5	
	5	DRM2/6	
	6	DRM3/7	
	7	DRM4/8	
	8	COM/DRM0	

Step 1: Prepare the communication cable.

Step 2: Thread the communication cable into the communication connector in sequence, insert communication wires to the communication terminal, and assemble the communication terminal into the communication connector.

Step 3: Connect the communication connector into the communication port on the inverter.

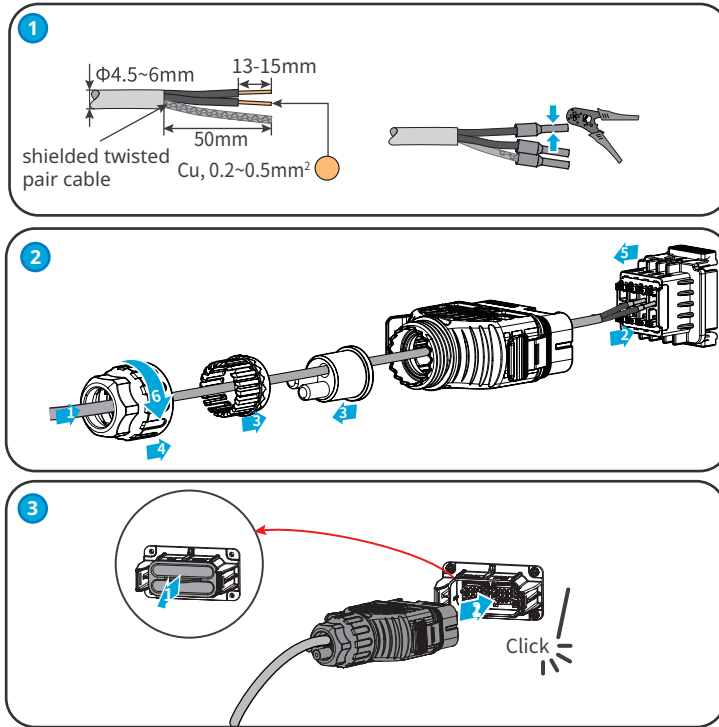

6.5.4 Installing the Smart Dongle (optional)

Plug a smart dongle into the inverter to establish a connection between the inverter and the smartphone or web pages. The smart dongle can be a 4G , WiFi, bluetooth or WiFi+LAN module. Set inverter parameters, check running information and fault information, and observe system status in time via the smartphone or web pages.

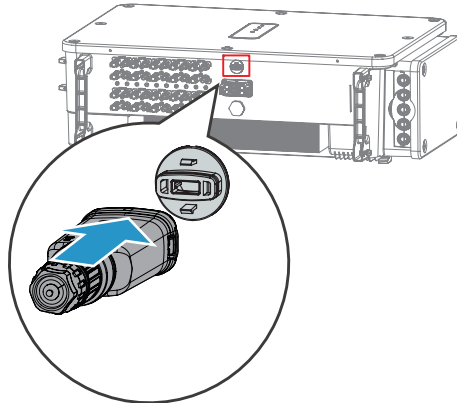

NOTICE

Refer to the delivered smart dongle user manual to get more introduction to the module. For more detailed information, visit <https://en.goodwe.com/>.

7 Equipment Commissioning

7.1 Check Items before Power On

No.	Check Item
1	The inverter is firmly installed in a clean place where is well-ventilated and easy to operate.
2	The PE cable, DC input cable, AC output cable, and communication cable are connected correctly and securely.
3	Cable ties are routed properly and evenly, and no burrs.
4	Unused ports and terminals are sealed.
5	The voltage and frequency at the connection point meet the on-grid requirements.

7.2 Power On





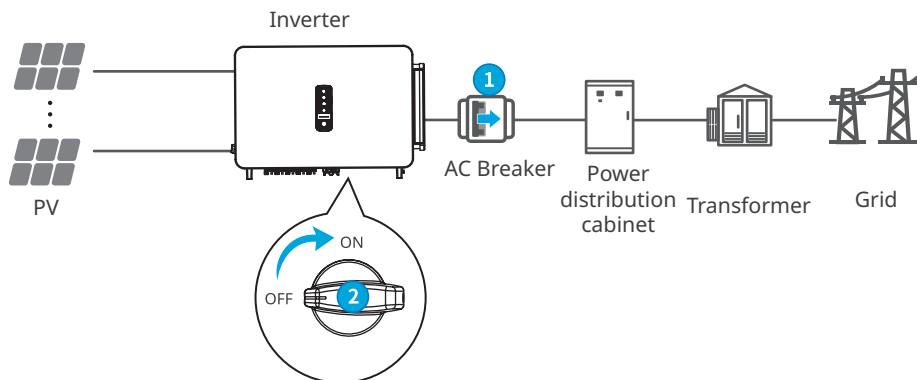













Step 1 Turn on the AC switch between the inverter and the utility grid.

Step 2 Turn on the DC switch of the inverter.



8 System Commissioning

8.1 Indicators and Button

Indicator	Status	Description
		ON = EQUIPMENT POWER ON
		OFF = EQUIPMENT POWER OFF
		ON = THE INVERTER IS FEEDING POWER
		OFF = THE INVERTER IS NOT FEEDING POWER
		SINGLE SLOW FLASH = SELF CHECK BEFORE CONNECTING TO THE GRID
		SINGLE FLASH = CONNECTING TO THE GRID
		ON = WIRELESS IS CONNECTED/ACTIVE
		BLINK 1 = WIRELESS SYSTEM IS RESETTING
		BLINK 2 = WIRELESS ROUTER NOT CONNECTED
		BLINK 4 = WIRELESS SERVER PROBLEM
		BLINK = RS485 IS CONNECTED
		OFF = WIRELESS IS NOT ACTIVE
		ON = A FAULT HAS OCCURRED
		OFF = NO FAULT

8.2 Setting Inverter Parameters via LCD

NOTICE

- The screen shots are for reference only. The actual display may differ.
- The name, range, and default value of the parameters is subject to change or adjust. The actual display prevails.
- To prevent the generating capacity from being influenced by wrong parameters, the power parameters should be set by professionals.

LCD Button Description

- Stop pressing the button for a period on any page, the LCD will get dark and go back to the initial page.
- Short press the button to switch menu or adjust parameter values.
- Long press the button to enter the submenu. After adjusting the parameter values, long press to save it.

Examples:

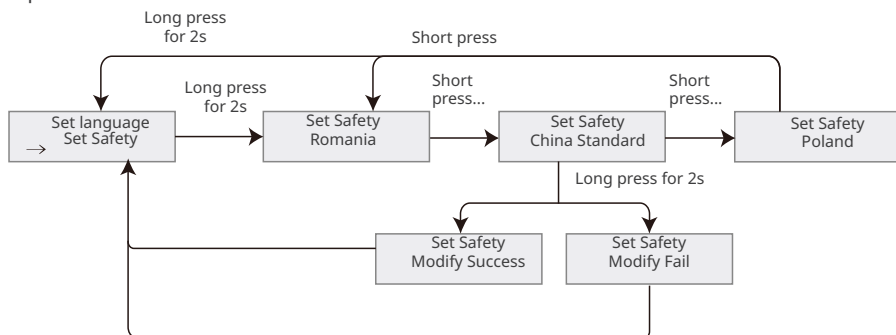

Australia:

- Tap **Home > Settings > Communication Setting > Privacy & Security** to set the parameters.
- Short press the button to switch menu to **Set Params Error History**.
- Long press the button for 2s to enter the **Set language Set Safety**.
- Long press for 2s to enter the **Set Safety**, short press to Australia.
- By short-pressing, you can select the Australia Region A/B/C.
- Long press for 2s to modify.

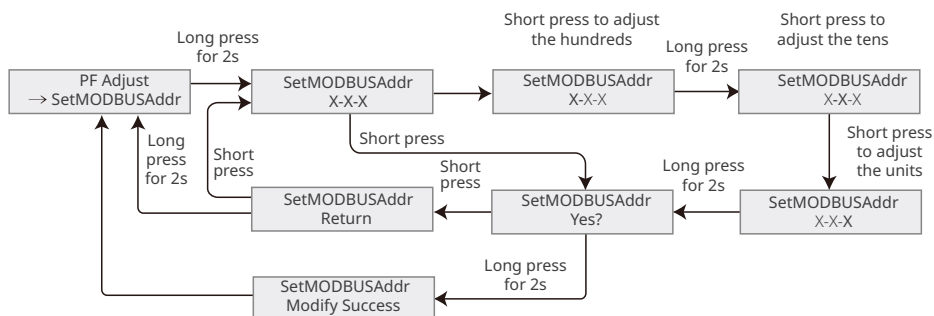

8.2.1 LCD Menu Introduction

This part describes the menu structure, allowing you view inverter information and set parameters more conveniently.

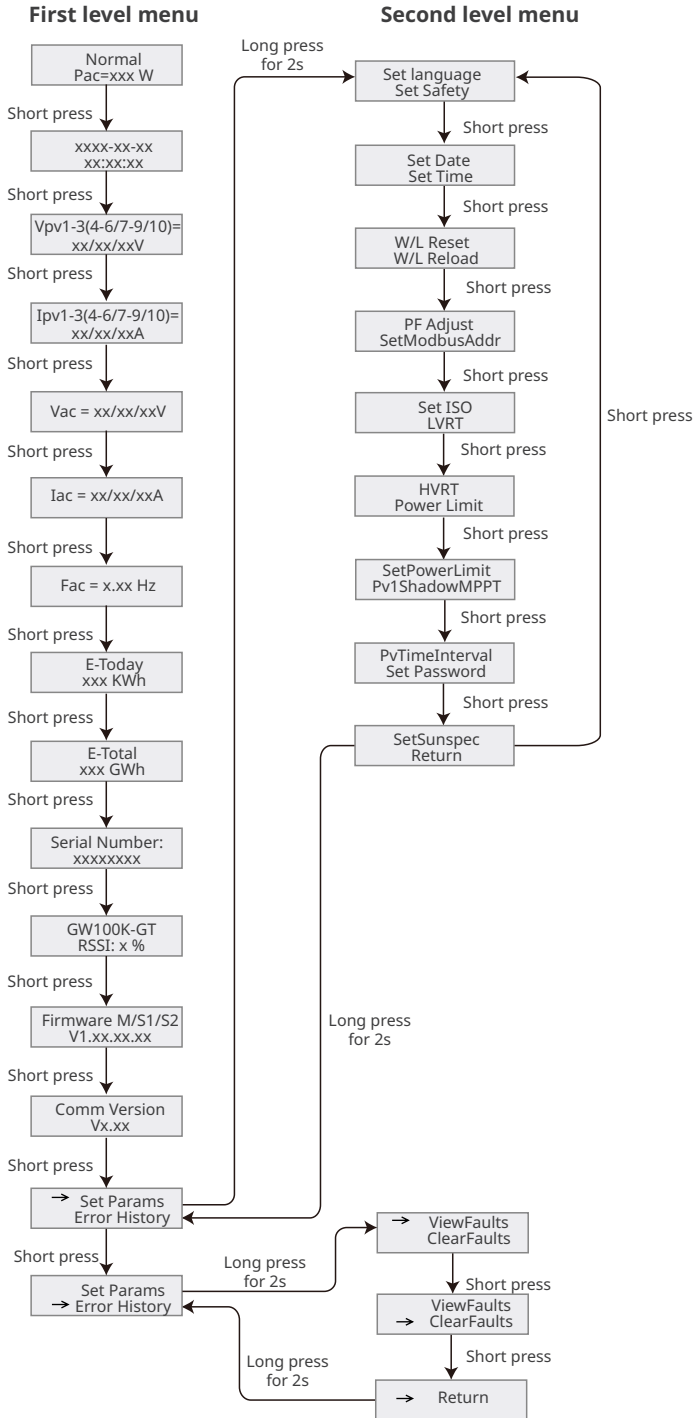

8.2.2 Inverter Parameter Introduction

Parameters	Description
Normal	Home page. Indicates the real-time power of the inverter.
2022-02-14 09:01:10	Check the time of the country/region.
VPv1	Check the DC input voltage of the inverter.
IPv1	Check the DC input current of the inverter.
Vac	Check the voltage of the utility grid.
Iac	Check the AC output current of the inverter.
Fac	Check the frequency of the utility grid.
E-Today	Check the generated power of the system for that day.
E-Total	Check the total generated power of the system.
Serial Number	Check the serial number of the inverter.
GW100K-GT RSSI	Check the signal strength of the smart dongle.
Firmware M/S1/S2	Check the firmware version.
Comm Version	Check the ARM software version.
Set Safety	Set the safety country/region in compliance with the local grid standards and application scenario of the inverter.
Set Date	Set time according to the actual time in the country/region where the inverter is located.
Set Time	
Set Password	The password can be changed. Keep the changed password in mind after changing it. Contact the after-sales service if you forget the password.
W/L Reset	Power off and restart the smart dongle.
W/L Reload	Restore the factory settings of the smart dongle. Reconfigure the smart dongle network parameters after restoring the factory settings,
PF Adjust	Set the power factor of the inverter according to the actual situation.
SetModbusAddr	Set the actual Modbus address.
Set ISO	Indicates the PV-PE insulation resistance threshold value. When the detected value is under the set value, the IOS fault occurs.

Parameters	Description
LVRT	With LVRT on, the inverter will stay connected with the utility grid after a short-term utility grid low voltage exception occurs.
HVRT	With HVRT on, the inverter will stay connected with the utility grid after a short-term utility grid high voltage exception occurs.
Power Limit	Set the power feed back into the utility grid according to the actual situation.
SetPowerLimit	
ShadowMPPT	Enable the shadow scan function if the PV panels are shadowed.
PvTimeInterval	Set the scan time according to the actual needs.
SetSunspec	Set the Sunspeg based on the actual communication method.
ViewFaults	Check historical error message records of the inverter.
ClearFaults	Clear historical error message records of the inverter.

8.3 Setting Inverter Parameters via App

SolarGo is an application used to communicate with the inverter via Bluetooth module, WiFi module, Wi-Fi/LAN module, or 4G module. Commonly used functions:

1. Check the operating data, software version, alarms of the inverter, etc.
2. Set grid parameters and communication parameters of the inverter.
3. Maintain the equipment.

8.3.1 Downloading the App

Make sure that the mobile phone meets the following requirements:

- Mobile phone operating system: Android 4.3 or later, iOS 9.0 or later.
- The mobile phone can access the Internet.
- The mobile phone supports WLAN or Bluetooth.

Method 1: Search SolarGo in Google Play (Android) or App Store (iOS) to download and install the app.



Method 2: Scan the QR code below to download and install the app.



8.3.2 App Structure

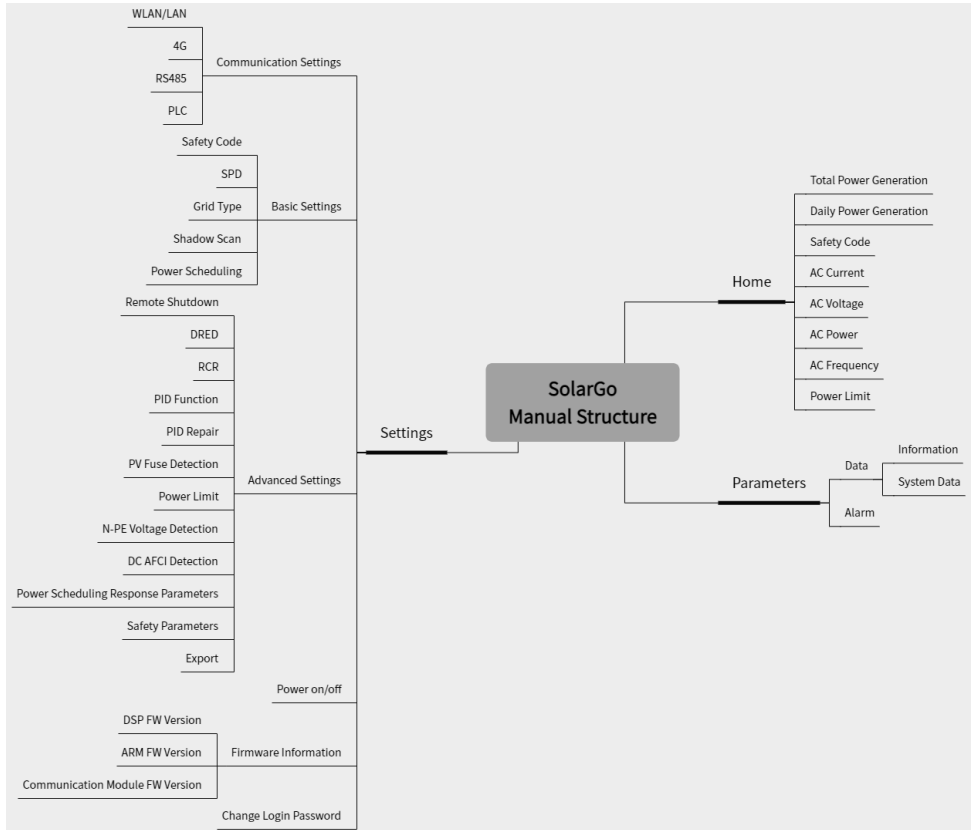



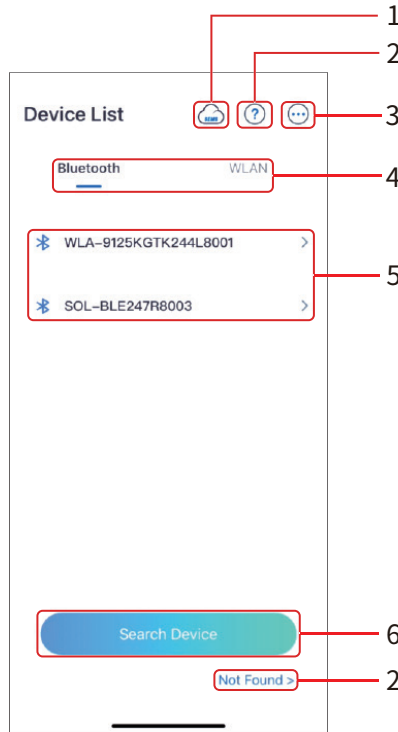

8.3.3 Introductions to Login Page

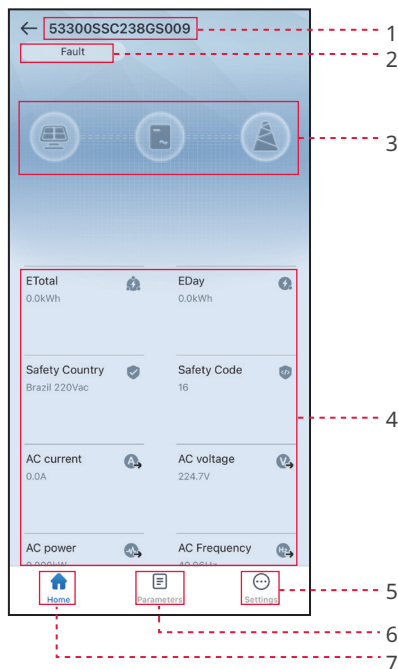

No.	Name/Icon	Description
1		Tap the icon to download the SEMS Portal app.
2		Tap to read the connection guide.
	Not found	
3		<ul style="list-style-type: none"> Check information such as app version, local contacts, etc. Settings like data update , language, temperature unit, etc.
4	Bluetooth/WiFi	Select based on actual communication method. If you have any problems, tap or NOT Found to read the connection guide.
5	Device List	<ul style="list-style-type: none"> The list of all devices. The last digits of the device name are normally the serial number of the device. Select the device by finding the serial number of the master inverter when multi inverters are parallel connected. The device name varies depending on the inverter model or smart dongle: <ul style="list-style-type: none"> Wi-Fi/LAN Kit, Wi-Fi Kit, Wi-Fi Box: Solar-WiFi*** External or integrated bluetooth module: SOL-BLE*** WiFi/LAN Kit-20: WLA-*** WiFi Kit-20: WFA-***
6	Search Device	Tap Search Device if the device is not found.

8.3.4 GUI Introductions to Grid-Tied PV Inverters



No.	Name/Icon	Description
1	Serial Number	Serial number of the connected inverter.
2	Device Status	Indicates the status of the inverter, such as Working, Fault , etc.
3	Energy Flow Chart	Indicates the energy flow chart of the PV system. The actual page prevails.
4	System Status	Indicates the working status of the PV system, such as ETotal, Safety Country, AC Current, AC Voltage , etc.
5		Home. Tap Home to check Serial Number, Device Status, Energy Flow Chart, System Status , etc.
6		Parameters. Tap Parameters to check the inverter Data , like Device Model, FW Version, PV, AC Current, AC Voltage , etc.. Or check Alarm like Utility Loss, Undervoltage , etc.. The Alarm will be occurred when there is earth fault detected.
7		Settings. Tap Settings to set parameters like Safety Code, Communication Settings, Power Limit, Firmware Update, AFCI Detection, Equipment Power Supply , etc..

8.3.5 App Operations for Grid-Tied PV Inverters

NOTICE

- All the user interface (UI) screenshots or words in this document are based on **SolarGo app V5.6.2**. The UI may be different due to the version upgrade. The screenshots, words or data are for reference only.
- The method to set parameters is the same for all inverters. But the parameters displayed varies based on the equipment model and safety code. Refer to the actual interface display for specific parameters.
- Before setting any parameters, read through user manual of the app and the inverter or charger to learn the product functions and features. When the inverter parameters are set improperly, the inverter may fail to connect to the utility grid or fail to connect to the utility grid in compliance with related requirements and damage the battery, which will affect the inverter's power generation.

Log In as Grid-Tied PV Inverter

NOTICE

- Log in using the initial password for the first time and change the password as soon as possible. To ensure account security, you are advised to change the password periodically and keep the new password in mind.
- The screenshots in this chapter are based on WiFi or Bluetooth login.

Step 1 Ensure that the inverter is power on, both the inverter and the smart dongle are working properly.

Step 2 Tap **Bluetooth** or **WiFi** tab on the homepage of SolarGo app based on the communication method.

Step 3 (optional): If you choose to connect the device via WiFi, open the WiFi settings of your phone first and connect to the inverter's WiFi signal (Solar-WiFi***). Default password: 12345678.

Step 4 Pull down or tap **Search Device** to refresh the device list. Find the device by the the inverter serial number. Tap the device name to log in. Select the device by checking the serial number of the master inverter when multi inverters are parallel connected.

Step 5 (optional) For first connection with the device via Bluetooth, there will be a Bluetooth pairing prompt, tap **Pair** to continue the connection.

Step 6 Log in as an Owner or an installer. Initial password: 1234.

Step 7 (optional) If connecting via Solar-WiFi***, modify the initial WiFi password following the prompts. If connecting via WLA-*** or WFA-***, modify the initial login password following the prompts.

Step 8 (Optional) If connecting via WLA-*** or WFA-***, enable **Bluetooth Stays On** following the prompts as entering the device details page. Otherwise, the bluetooth signal of the device will be off after disconnection.

Connecting the inverter via WLAN

NOTICE

- If the SolarGo app version is upgraded to V5.6.2 or later, a **Reminder** will pop up every time you connect to the inverter via WLAN to prompt you to change the password. If you want to permanently close the pop-up window, tap **Never Show Again**.
- If you forget the new password, reset the password by the smart dongle or the LCD of the inverter. Restore the dongle to reset the password will loss network configurations before.

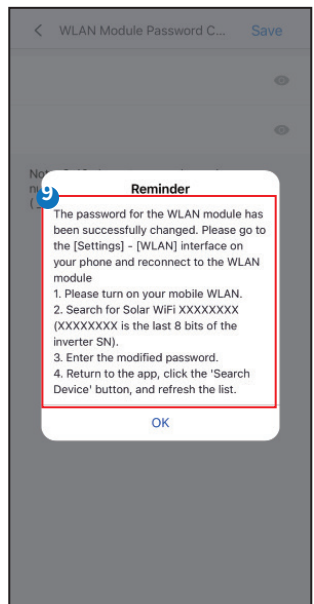
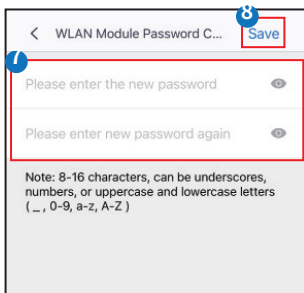
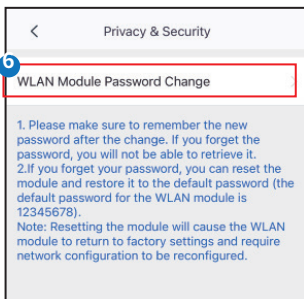
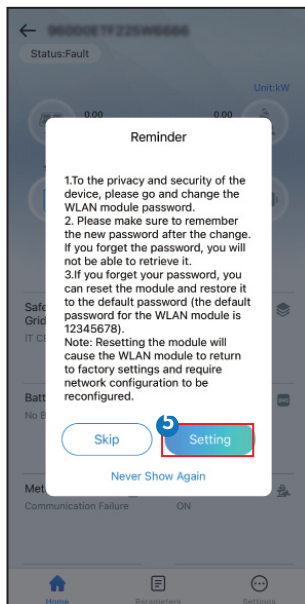
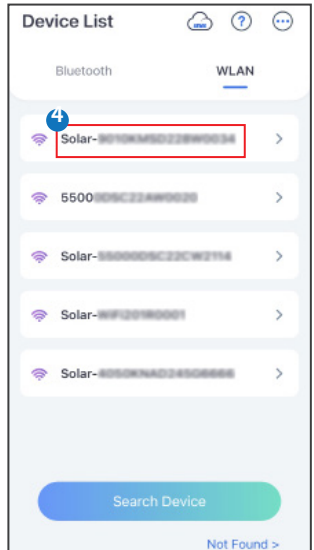
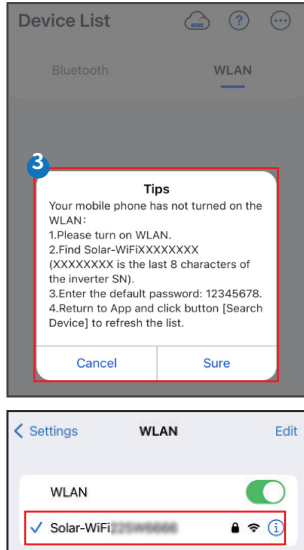
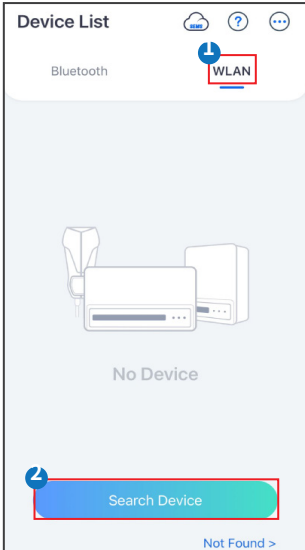

Connecting the inverter via Bluetooth

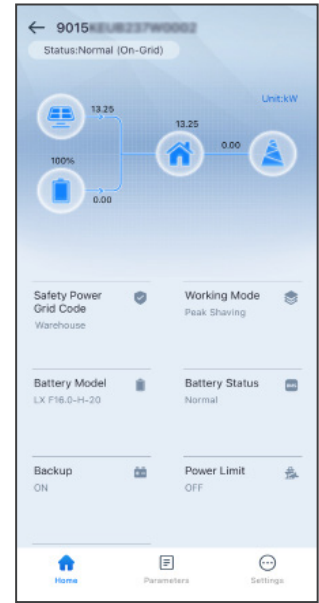
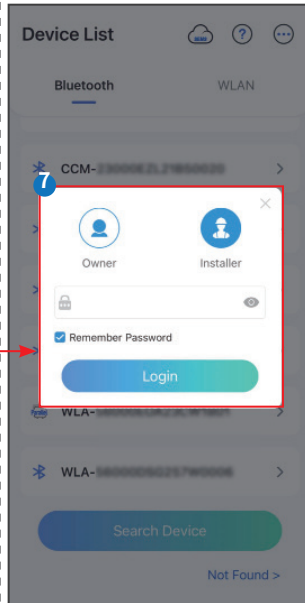
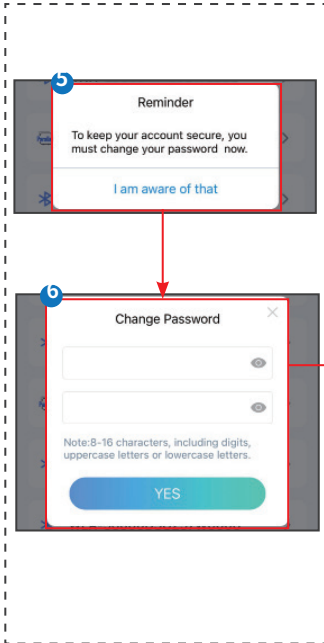
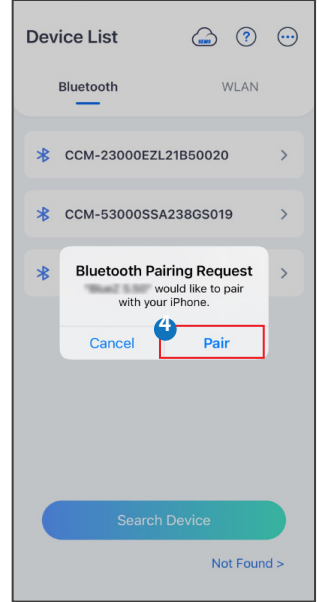
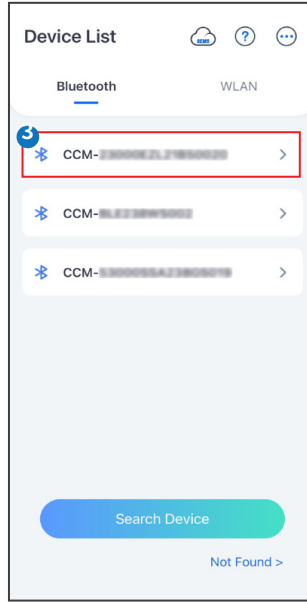
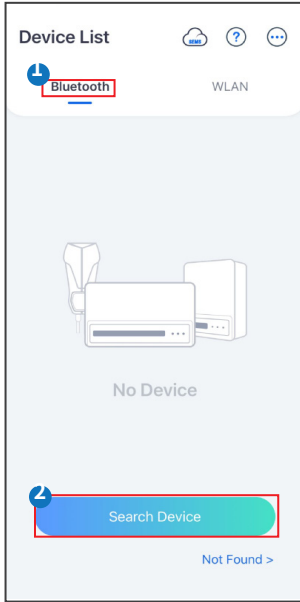

8.3.6 Settings

Setting Privacy and Security

Type I

Step 1 Tap **Home** > **Settings** > **Communication Setting** > **Privacy & Security** to set the parameters.

Step 2 Set the new password for the WiFi hotspot of the smart dongle, and tap **Save**. **Step 3**

Open the WiFi settings of your phone and connect to the inverter's WiFi signal (Solar-WiFi****) with the new password.

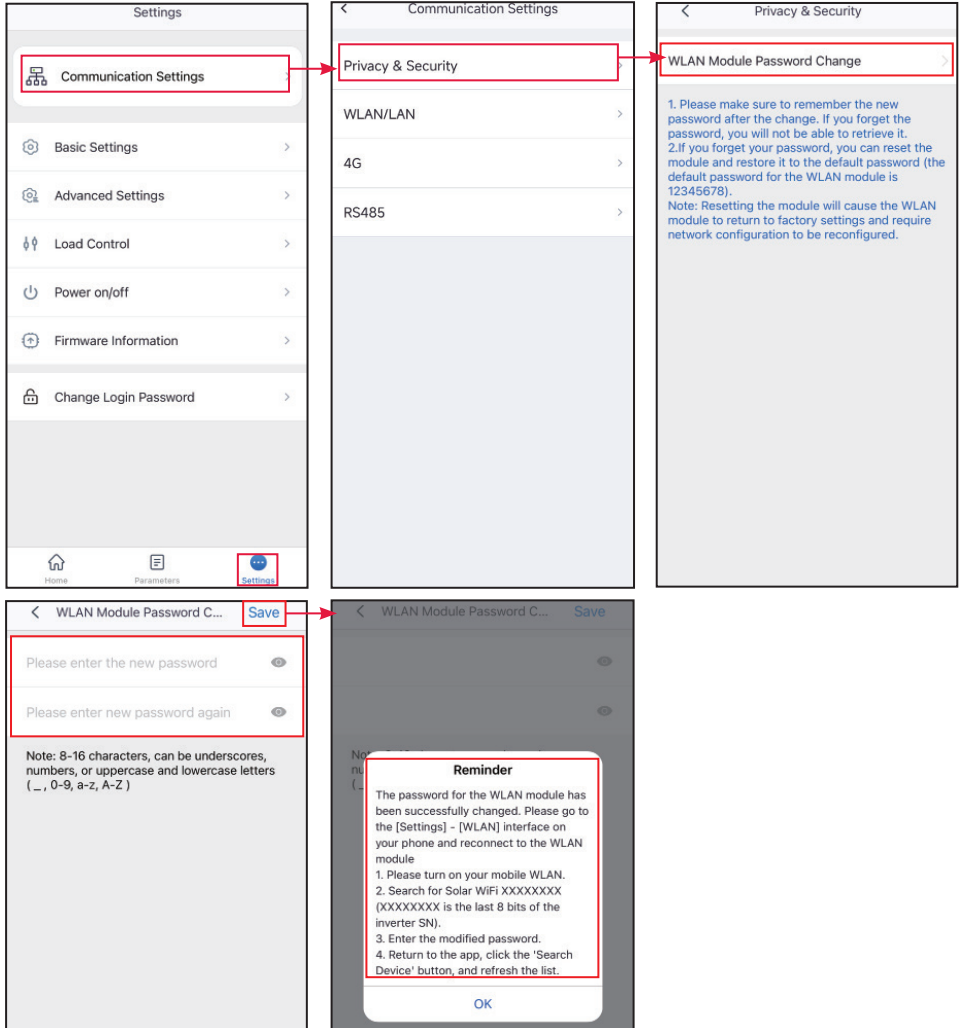

Type II

Step 1 Tap **Home > Settings > Communication Setting > Privacy & Security** to set the parameters.

Step 2 Enable **Bluetooth Stays On** or **WLAN Control** based on actual needs.



No.	Parameters	Description
1	Bluetooth Stays On	Disabled by default. Enable the function, the bluetooth of the device will be contentious on to keep connected to SolarGo. Otherwise, the bluetooth will be off in 5 minutes, and the device will be disconnected from SolarGo.
2	WLAN Control	Disabled by default. Enable the function, the device and the SolarGo can be connected through the WLAN when they are on the same LAN. Otherwise, they cannot be connected even if they are on the same LAN.

Configuring Network

Step 1 Tap **Home** > **Settings** > **Communication Setting** > **WLAN/LAN** to set the parameters.

Step 2 Configure the **WLAN** or **LAN** parameters based on actual needs.

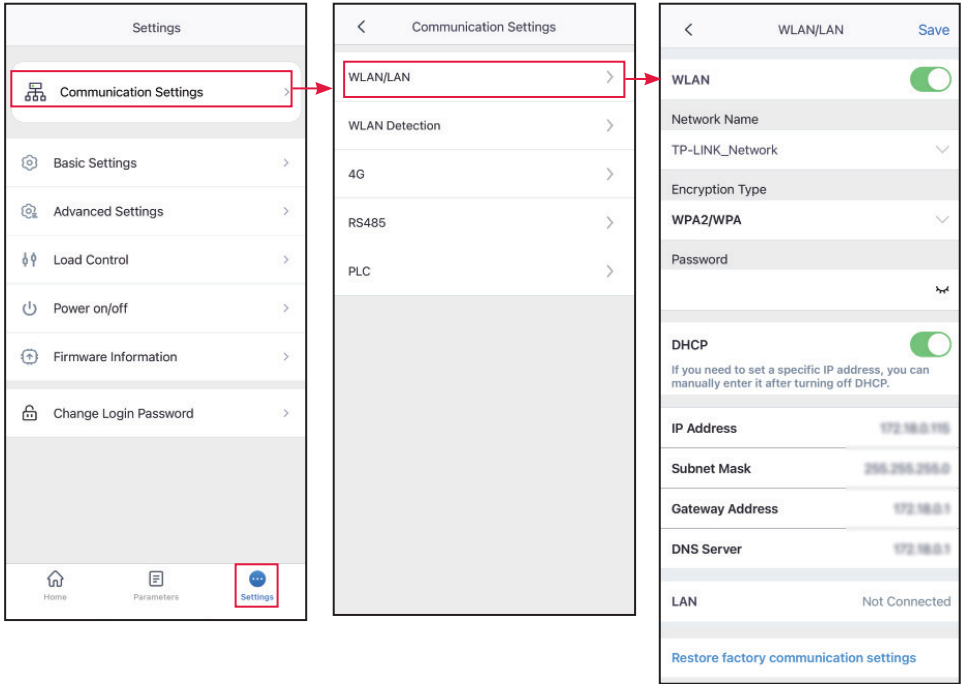

No.	Parameters	Description
1	Network Name	Only for WLAN. Select WiFi based on the actual connecting.
2	Password	Only for WLAN. WiFi password for the actual connected network.
3	DHCP	<ul style="list-style-type: none"> Enable DHCP when the router is in dynamic IP mode. Disable DHCP when a switch is used or the router is in static IP mode.
4	IP Address	<ul style="list-style-type: none"> Do not configure the parameters when DHCP is enabled. Configure the parameters according to the router or switch information when DHCP is disabled.
5	Subnet Mask	
6	Gateway Address	
7	DNS Server	

Configuring 4G Parameters

NOTICE

- APN Settings can only be used to configure the SIM card information of 4G communication device.
- Configure the APN settings through a bluetooth module or a WiFi module before installing a 4G module.

Step 1 Tap **Home** > **Settings** > **Communication Setting** > **4G** to set the parameters.

Step 2 Configure the **4G** parameters based on actual needs.

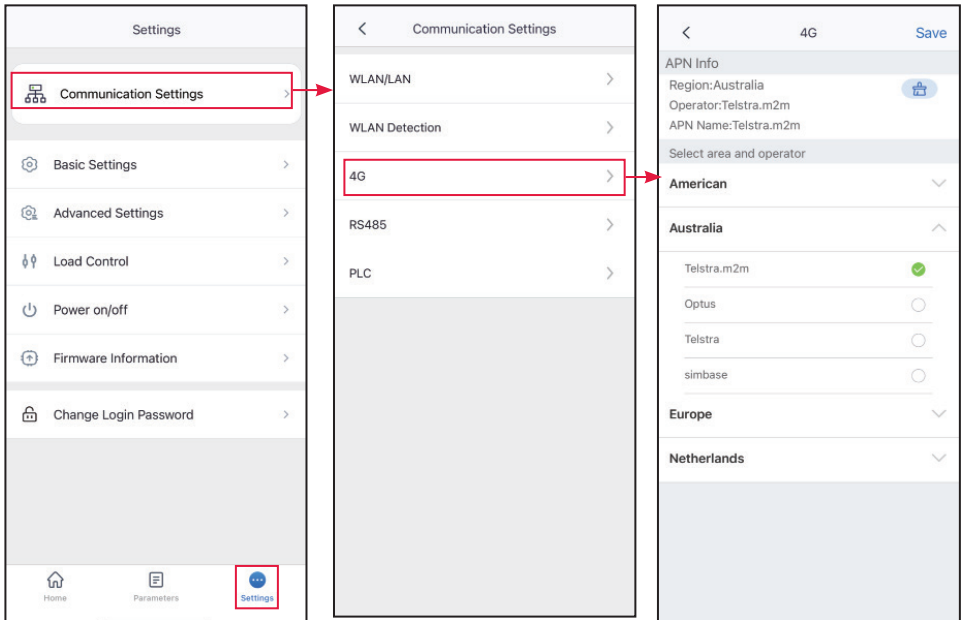

Configuring RS485 Parameters

NOTICE

Set the communication address of the inverter. For a single inverter, the address is set based on actual needs. For multi connected inverters, the address of each inverter should be different while cannot be 247.

Step 1 Tap **Home** > **Settings** > **Communication Setting** > **RS485**, to set the RS485 parameters.

Step 2 Set **Protocol Type**, **COM Address** and **Baud Rate** based on actual needs.

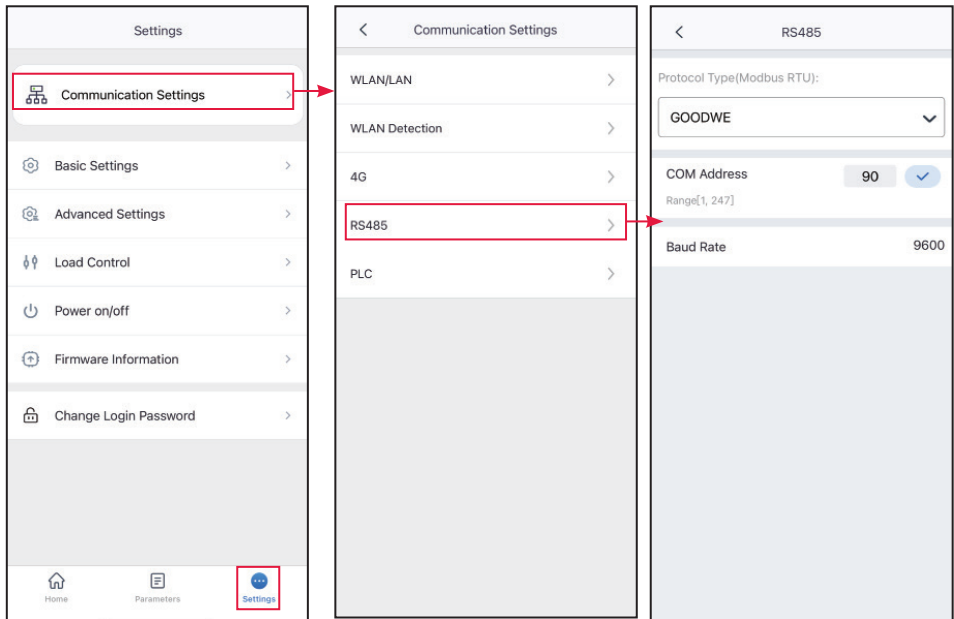

Configuring PLC Parameters

Only for PLC communication. Set parameters based on actual connected

Step 1 Tap **Home** > **Settings** > **Communication Settings** > **PLC Setting** to set the parameters.

Step 2 Set the **Transformer No.** based on actual needs.

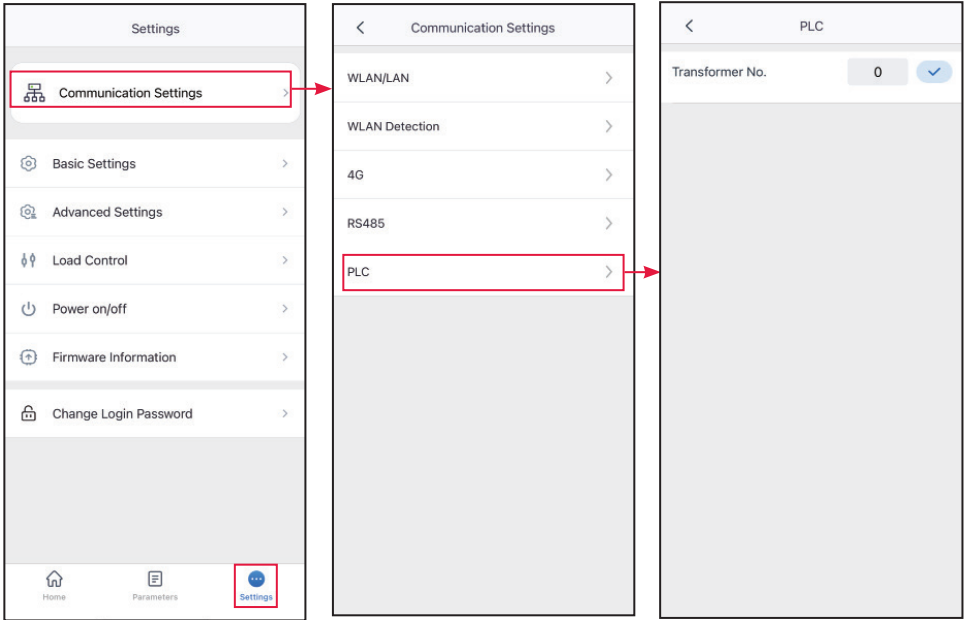

WLAN Detection

Step 1 Tap **Home** > **Settings** > **Communication Settings** > **WLAN Detection**.

Step 2 Tap **Diagnosis** to check the network connection status.

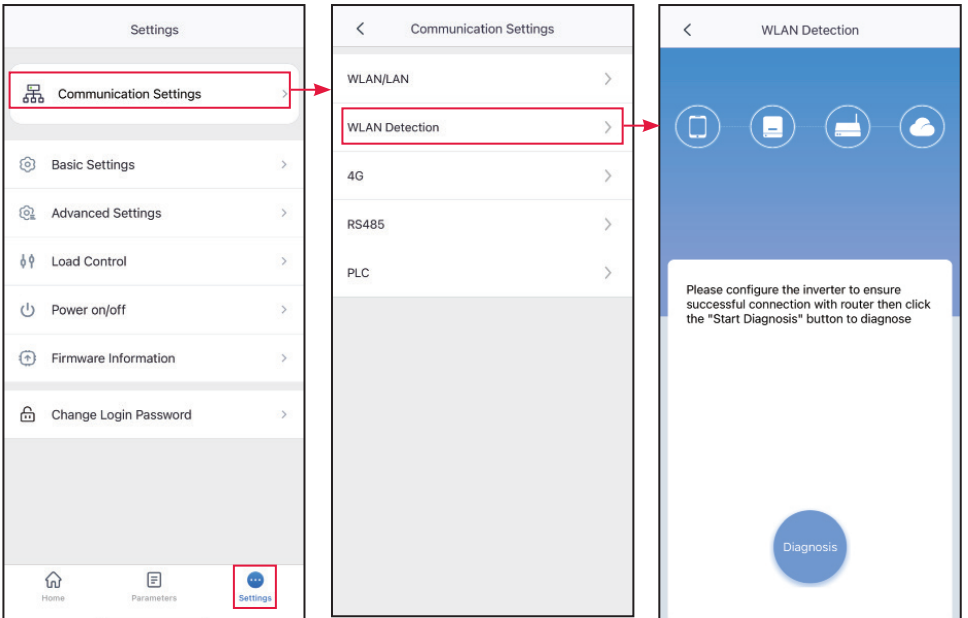

Setting Basic Information (Owner/Installer)

Step 1 Tap **Home** > **Settings** > **Basic Settings**, to set the basic parameters according to the inverter location and actual application scenarios.

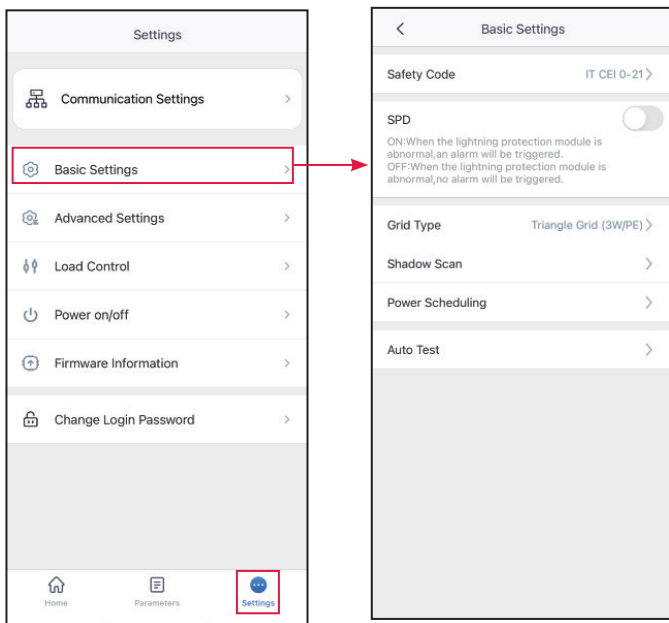

No.	Parameters	Description
1	Safety Code	<ul style="list-style-type: none"> Set the safety country in compliance with local grid standards and application scenario of the inverter. The default parameters varies depending on different safety code. The safety parameters can be changed in Safety Parameters. Tap Safety Code > Export to export the default value of some parameters. Contact the after-sales service for the initial password.
2	SPD	After enabling this function, when the SPD module is abnormal, there will be SPD module exception alarm prompt.
3	Grid Type	Set the grid type according to the actual grid type. Supported grid type: star grid and triangle grid.
4	Shadow Scan	Enable the shadow scan function if the PV panels are shadowed. Set the Shadow Scan interval and MPPT shadow scan if the inverter supports.
5	DC Tripping	Enable the DC tripping function to disconnect the DC switch automatically when the inverter fails.
6	Power scheduling	Set the output value of the inverter.
7	Auto Test	Enable Auto Test to set auto test for grid tying in compliance with local grid standards and requirements.

Advanced Settings

Enable Remote Shutdown/DRED/RCR before connecting the third party DRED, remote shutdown, or RCR device to comply with local laws and regulations.

Starting/Stopping the Grid

Step 1 Tap **Home** > **Settings** > **Power on/off**.

Step 2 Tap **Start** to start connecting to the grid. Or tap **Stop** to end connection.

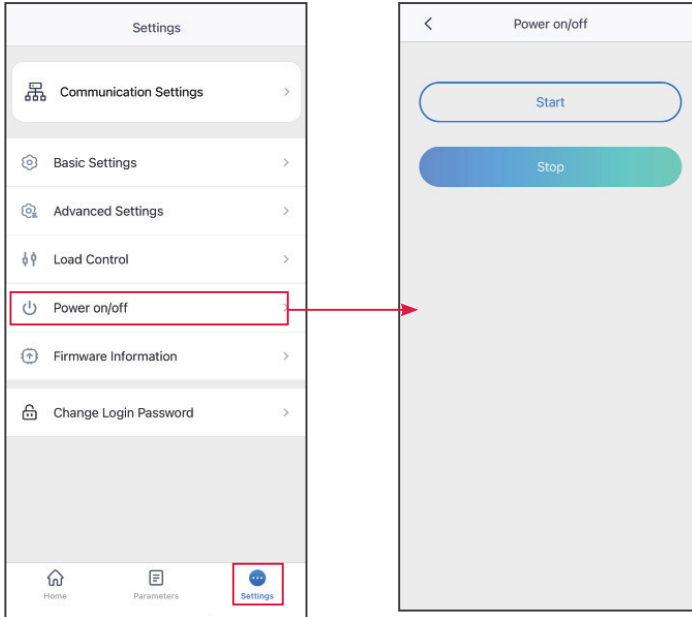

Upgrading the Firmware

NOTICE

- Upgrade the DSP version, ARM version of the inverter , or firmware version of the smart dongle. Some devices do not support upgrading the firmware version through SolarGo app.
- If the Firmware Upgrade dialog box pops up once logging into the app, click **Firmware Upgrade** to directly go to the firmware information page.

Type I

NOTICE

- When prompted by a red dot on the right of the **Firmware Information**, click to get the firmware update information.
- During the upgrade process, ensure that the network is stable and the device remains connected to SolarGo, otherwise the upgrade may fail.

Step 1 Tap **Home** > **Settings** > **Firmware Information** to check the firmware version.

Step 2 (Optional) Tap Check For Update to check whether there is a latest version to be updated.

Step 3 Tap **Firmware Information** as prompted to enter the firmware upgrade page.

Step 4 (Optional) Tap Learn More to check the firmware related information, such as **Current Version**, **New Version**, **Update Record**, etc.

Step 5 Tap **Upgrade** and follow the prompts to complete the upgrading.

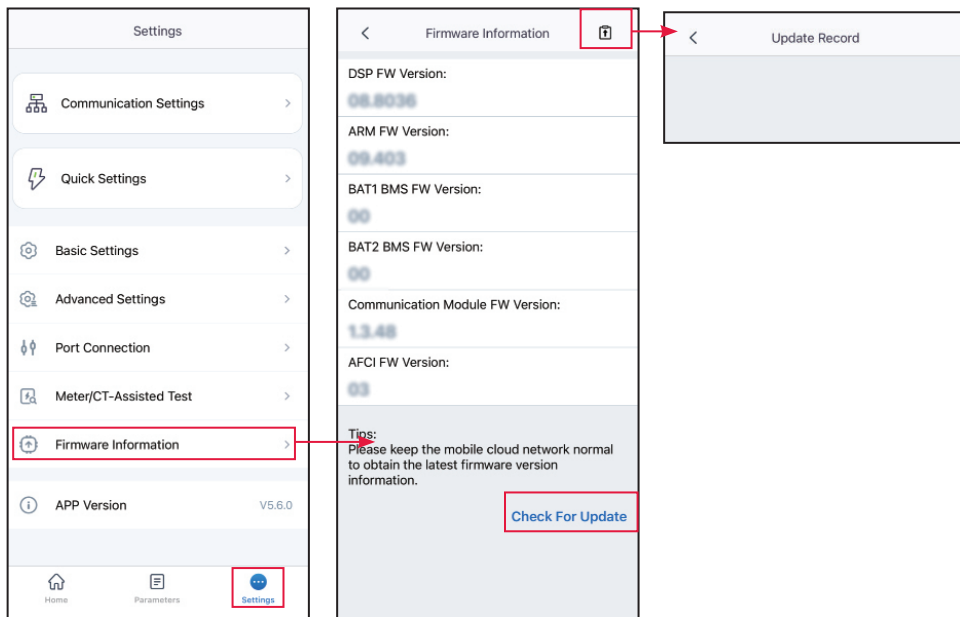

Type II

NOTICE

- The automatic upgrade function is allowed only when a WiFi/LAN Kit-20 or WiFi Kit-20 module is applied, and the module firmware version is V2.0.1 and above.
- After enabling the auto-upgrade function, if there is any update and the device is connected to the network, the kit firmware version can be automatically upgraded.

Step 1 Tap **Home** > **Settings** > **Firmware Information** to check the firmware version.

Step 2 Tap or to enable or disable the **Automatic Upgrade**.

Change the Login Password

NOTICE

The login password can be changed. Keep the changed password in mind after changing it. Contact the after-sales service if you forget the password.

Step 1 Tap **Home** > **Settings** > **Change Login Password**, to change the password.

Step 2 Change the password based on actual needs.

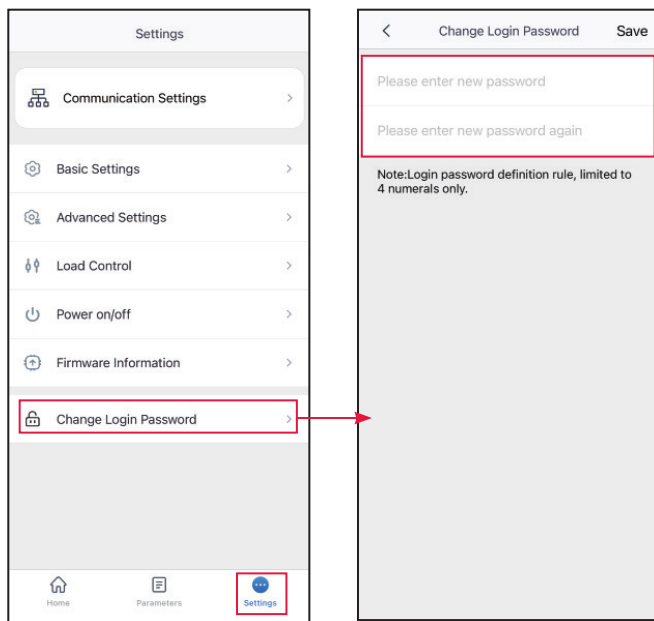

For more details, refer to the SolarGo APP User Manual. Scan the QR code or visit https://en.goodwe.com/Ftp/EN/Downloads/User%20Manual/GW_SolarGo_User%20Manual-EN.pdf to get the user manual.



SolarGo App
User Manual

8.4 SEMS Portal App Overview

SEMS Portal App is a monitoring platform. Commonly used functions are as follows:

1. Manage the organization or User information;
2. Add and monitor the power plant information;
3. Equipment maintenance.

8.4.1 Login Page of SEMS Portal App

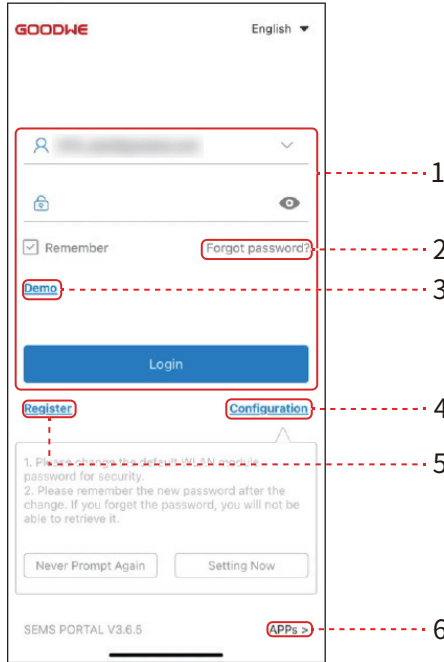

No.	Name/Icon	Description
1	Login Area	Enter the user name, password to login to the app.
2	Forget Password	Tap to reset the password by verifying the account.
3	Demo	Tap to enter the sample plant page. The sample page only displays contents with Visitor account, which is for reference only.
4	Configuration	Configure WiFi parameters to establish communication between the inverter and the server and realize remote monitoring and managing.
5	Register	Tap to register an end-user account. Contact the manufacturer or the company as prompted if you need a company account.
6	Demo	Tap to enter the sample plant page. The sample page only displays contents with Visitor account, which is for reference only.

8.4.2 Home Page of SEMS Portal App

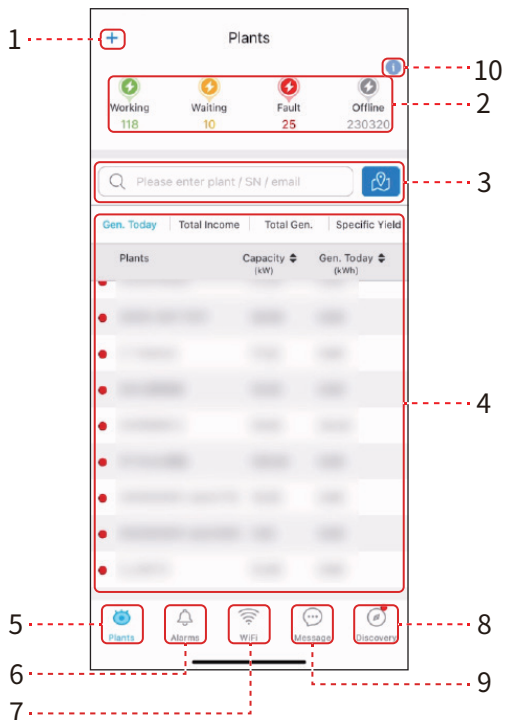

No.	Name/Icon	Description
1		Create a new power plant.
2	Plant status	The summary of the plants working information under the account.
3	Find the plant	Find the plant by entering the plant name, device SN, Email address, or map.
4	Generation statistics	The working information of a single plant. Tap the plant name to check the detailed information of the plant, such as plant name, location, power, capacity, generation today, total generation, etc.
5	Plants	Plant monitoring page.
6	Alarms	Check all alarms, happening alarms, and recovered alarms.

No.	Name/Icon	Description
7	WiFi	Complete WiFi configurations when a Wi-Fi Kit dongle is used.
8	Message	Message Set and check system messages.
9	Discovery	Discovery To Edit the account, create My QR Code, set Income Settings , etc.
10	⚠	Fault. Used to view all faults, unresolved faults, and recovered faults

8.4.3 Monitoring Power Plant

Checking the Plant Information

Log in the SEMS Portal App with the account and password. The overall working situation of all power plants under this account will be displayed. Click Monitoring to enter the power plant monitoring interface to view all power plant information.

The displayed content of different interfaces of power plant equipment varies, please refer to the actual situation.

Step 1: (Optional) Search the plant name, inverter SN, or Email to find out the plant quickly. Or tap the map icon to search the plant.

Step 2 Tap the plant name in the plant list or the plant icon in the map to check detailed information about the plant.

Step 3 Check the plant information, power generation situation, device information, faults, etc.

Viewing Alarm Information

Step 1 Tap Alarm tab and enter the Alarm Details page.

Step 2 (optional) Enter the plant name, inverter SN, or owner's Email address in the search bar to find out the plant which is alarming.

Step 3 Tap the alarm name to check the alarm details.

For more details, refer to the SEMS Portal User Manual. Scan the QR code or visit https://en.goodwe.com/Ftp/EN/Downloads/User%20Manual/GW_SEMS%20Portal-User%20Manual-EN.pdf to get the user manual.



SEMS Portal



SEMS Portal
User Manual

9 Maintenance

9.1 Power Off the Inverter

DANGER

- Power off the inverter before operations and maintenance. Otherwise, the inverter may be damaged or electric shocks may occur.
- Delayed discharge. Wait until the components are discharged after power off.

Step 1 (Recommended) Issue a command to the inverter for halting the grid via SolarGo APP.

Step 2 Turn off the AC switch between the inverter and the utility grid.

Step 3 Turn off the DC switch of the inverter.

9.2 Removing the Inverter

WARNING

- Make sure that the inverter is powered off.
- Wear proper PPE before any operations.

Step 1 Disconnect all the cables, including DC cables, AC cables, communication cables, the smart dongle, and PE cables.

Step 2 Handle or hoist the inverter to take it down from the wall or the bracket.

Step 3 Remove the bracket.

Step 4 Store the inverter properly. If the inverter needs to be used later, ensure that the storage conditions meet the requirements.

9.3 Disposing of the Inverter

If the inverter cannot work any more, dispose of it according to the local disposal requirements for electrical equipment waste. Do not dispose of it as household waste.

9.4 Troubleshooting

Perform troubleshooting according to the following methods. Contact the after-sales service if these methods do not work.

Collect the information below before contacting the after-sales service, so that the problems can be solved quickly.

1. Inverter information like serial number, software version, installation date, fault time, fault frequency, etc.
2. Installation environment, including weather conditions, whether the PV modules are sheltered or shadowed, etc. It is recommended to provide some photos and videos to assist in analyzing the problem.
3. Utility grid situation.

No.	Fault	Cause	Solutions
1	SPI Comm Fail	<ol style="list-style-type: none"> 1. The chip is not powered on. 2. The program version of the chip is wrong. 	Disconnect the AC output switch and DC input switch, then connect them 5 minutes later. Contact the dealer or the after-sales service if the problem persists.
2	EEPROM Fail	The internal memory Flash is abnormal.	
3	Fac Fail	The utility grid frequency is out of the allowed range.	<ol style="list-style-type: none"> 1. If the problem occurs occasionally, the utility grid may be abnormal temporarily. The inverter will recover automatically after detecting that the utility grid is normal. 2. If the problem occurs frequently, check whether the grid frequency is within the permissible range. <ul style="list-style-type: none"> • Contact the local power company if the grid frequency exceeds the permissible range. • Contact the dealer or the after-sales service if the grid frequency is within the permissible range.
4	DC-SPD	The inverter is struck by lightning.	<ol style="list-style-type: none"> 1. The inverter is struck by lightning. 2. Disconnect the AC output switch and DC input switch, then connect them 5 minutes later. Contact the dealer or the after-sales service if the problem persists.

No.	Fault	Cause	Solutions
5	Night DCSPS Fault	<ol style="list-style-type: none"> 1. Temporary abnormality caused by environmental factors. 2. Internal components of the inverter are damaged. 	<p>Disconnect the AC output switch and DC input switch, then connect them 5 minutes later. Contact the dealer or the after-sales service if the problem persists.</p>
6	Relay Fail	<ol style="list-style-type: none"> 1. The relay is abnormal or short-circuited. 2. The control circuit is abnormal. 3. The AC cable connection is abnormal, like a virtual connection or short circuit. 	
7	BUS-start Fail	<ol style="list-style-type: none"> 1. The output power of the PV string is too low. 2. The control circuit is abnormal. 	
8	PV Reverse Fault	The PV string is connected reversely.	Check whether the PV strings are connected reversely.
9	Night BUS Fault	<ol style="list-style-type: none"> 1. Utility grid power fails. 2. The AC cable is disconnected, or the AC breaker is off. 	Disconnect the AC output switch and DC input switch, then connect them 5 minutes later. Contact the dealer or the after-sales service if the problem persists.
10	CPLD Error	<ol style="list-style-type: none"> 1. Temporary abnormality caused by environmental factors. 2. Internal components of the inverter are damaged. 	Disconnect the AC output switch and DC input switch, then connect them 5 minutes later. Contact the dealer or the after-sales service if the problem persists.
11	DCI High	The equipment detects that the DC component of the internal output current exceeds the normal range.	Contact your dealer or after-sales service.
12	ISO Fail	<ol style="list-style-type: none"> 1. The PV string is short-circuited to the ground. 2. The PV system is in a moist environment and the circuit is not well insulated to the ground. 	<ol style="list-style-type: none"> 1. Check whether the PV input cables are broken. 2. Check whether the module frames and the metal bracket are securely grounded. 3. Check whether the AC side is properly grounded.

No.	Fault	Cause	Solutions
13	Vac Failure	The utility grid voltage is out of the allowed range.	<ol style="list-style-type: none"> 1. Check whether the AC output voltage of the inverter meets the grid requirements. 2. Make sure that the phase sequence of the AC cables are connected correctly, and the neutral wire and PE cable are connected properly and firmly.
14	ExFan Failure	<ol style="list-style-type: none"> 1. The fan power supply is abnormal. 2. Mechanical exception. 3. The fan is aging and damaged. 	Disconnect the AC output switch and DC input switch, then connect them 5 minutes later. Contact the dealer or the after-sales service if the problem persists.
15	GFCI Chk Fail	The sampling of the GFCI HCT is abnormal.	
16	AFCI Fault	<ol style="list-style-type: none"> 1. The PV string terminal is not firmly connected. 2. The DC cable is broken. 	Please check whether the wiring of the PV modules are correct according to the requirements in the user manual.
17	Over Temperature	<ol style="list-style-type: none"> 1. The inverter is installed in a place with poor ventilation. 2. The ambient temperature exceeds 60°C. 3. A fault occurs in the internal fan of the inverter. 	<ol style="list-style-type: none"> 1. Check the ventilation and the ambient temperature at the installation point. 2. If the ventilation is poor or the ambient temperature is too high, improve the ventilation and heat dissipation. 3. Contact the dealer or after-sales service if both the ventilation and the ambient temperature are proper.
18	InFan Fail	<ol style="list-style-type: none"> 1. The fan power supply is abnormal. 2. Mechanical exception. 3. The fan is aging and damaged. 	Disconnect the AC output switch and DC input switch, then connect them 5 minutes later. Contact the dealer or the after-sales service if the problem persists.
19	Gnd I Fail	The input insulation resistance value to the ground decreases when the inverter is operating.	<ol style="list-style-type: none"> 1. Check whether the working environment of the inverter meets the requirements. For example, the fault may be occurred due to high humidity in rainy days, . 2. Make sure that the components are properly grounded and the AC side is properly grounded.
20	Utility Loss	<ol style="list-style-type: none"> 1. Utility grid power fails. 2. The AC cable is disconnected or the AC breake is off. 	<ol style="list-style-type: none"> 1. The alarm is automatically cleared after thegrid power supply is restored. 2. Check whether the AC cable is connected andthe AC breaker is on.

No.	Fault	Cause	Solutions
21	AC HCT Fail	The HCT sensor is abnormal.	Disconnect the AC output switch and DC input switch, then connect them 5 minutes later. Contact the dealer or the after-sales service if the problem persists.
22	Relay Fault	1. The relay is abnormal or short-circuited. 2. The sampling circuit of the relay is abnormal.	
23	GFCI Chk Fail	The sampling of the GFCI HCT is abnormal.	
24	SPD Fail	The inverter is struck by lightning.	1. Improve the lightning protection facilities around the inverter. 2. Disconnect the AC output switch and DC input switch, then connect them 5 minutes later. Contact the dealer or the after-sales service if the problem persists.
25	Ref-V Chk Fail	The reference circuit fails.	Disconnect the AC output switch and DC input switch, then connect them 5 minutes later. Contact the dealer or the after-sales service if the problem persists.
26	HCT Chk Fail	The AC sensor is abnormal in sampling.	
27	PID Error	1. Abnormal Ground 2. The PID module is abnormal.	1. Check whether the DC wirings and AC wirings are abnormal. 2. Check whether the PID module is abnormal 3. Contact your dealer or after-sales service.
28	PV Over Curr	1. The PV module configuration is not proper. 2. The hardware is damaged.	Disconnect the AC output switch and DC input switch, then connect them 5 minutes later. Contact the dealer or the after-sales service if the problem persists.
29	Model Error	1. Temporary abnormality caused by environmental factors. 2. Internal components of the inverter are damaged.	
30	PV Short Failure	The hardware is abnormal.	Contact your dealer or after-sales service.
31	BUS-start Fail	1. The output power of the PV string is too low. 2. The control circuit is abnormal.	Disconnect the AC output switch and DC input switch, then connect them 5 minutes later. Contact the dealer or the after-sales service if the problem persists.
32	PV Over Voltage	Excess PV modules are connected in the series.	1. Check whether the PV string input voltage consistent with the value displayed on the LCD. 2. Check whether the PV string voltage meets the maximum input voltage requirements.

No.	Fault	Cause	Solutions
33	PV Voltage Low	Sun light is weak or changing abnormally.	<ol style="list-style-type: none"> 1. If the problem occurs occasionally, the reason might be abnormal sun light. The inverter will recover automatically without manual intervention. 2. If the problem occurs frequently, contact the dealer or the after-sales service.
34	PV HCT Fail	<ol style="list-style-type: none"> 1. Temporary abnormality caused by environmental factors. 2. Internal components of the inverter are damaged. 	<p>Disconnect the AC output switch and DC input switch, then connect them 5 minutes later. Contact the dealer or the after-sales service if the problem persists.</p>
35	PV Over Curr	<ol style="list-style-type: none"> 1. Temporary abnormality caused by environmental factors. 2. Internal components of the inverter are damaged. 	
36	BUS Unbalance	<ol style="list-style-type: none"> 1. The sampling circuit of the relay is abnormal. 2. Abnormal hardwares 	
37	DC Bus High	<ol style="list-style-type: none"> 1. The PV voltage is too high. 2. The sampling of the inverter BUS voltage is abnormal. 	
38	PV Continuous Hardware Overcurrent	<ol style="list-style-type: none"> 1. The PV module configuration is not proper. 2. The hardware is damaged. 	

9.5 Routine Maintenance



Power off the inverter before operations and maintenance. Otherwise, the inverter may be damaged or electric shocks may occur.

Maintaining Item	Maintaining Method	Maintaining Period
System Clean	Check the heat sink, air intake, and air outlet for foreign matter or dust.	Once 6-12 months
Fan	Check the fan for proper working status, low noise, and intact appearance.	Once a year
DC Switch	Turn the DC switch on and off ten consecutive times to make sure that it is working properly.	Once a year
Electrical Connection	Check whether the cables are securely connected. Check whether the cables are broken, or whether there is any exposed copper core.	Once 6-12 months
Sealing	Check whether all the terminals and ports are properly sealed. Reseal the cable hole if it is not sealed or too big.	Once a year
THDi Test	For Australia requirements, in the THDi test, there should add Zref between inverter and mains. Zref: Zmax or Zref (phase current>16A) Zref: L: 0.24 Ω + j0.15 Ω; N: 0.16 Ω + j0.10 Ω (phase current>16A, <21.7A) Zref: L: 0.15 Ω + j0.15 Ω; N: 0.1 Ω + j0.1 Ω (phase current>21.7A, <75A) Zref: ≥5% Un/Irated+j5% Un/Irated (phase current>75A)	As needed

Follow below steps to maintain the fans of GT inverters:

GT Series inverter is equipped with four fans on its left side. The fan should be cleaned yearly with a vacuum cleaner. For more thorough cleaning, completely remove the fans.

Disconnect the AC breaker first and then disconnect DC breaker.

Wait 5 minutes until the residual voltage has been released and the fans are no longer turning. Disassemble the fans (refer to the below figure).

1. Loosen the five screws with a screwdriver, then draw the fans from the cabinet slowly.

2. Open the lockers of the three fans connectors and remove them from housing, then take the fans away.

- Clean the ventilation net and the fan with a soft brush, a paint brush, a cloth, or compressed air.
- Reassemble the fans into the cabinet
- Please use towel to clean the heatsink once a year.

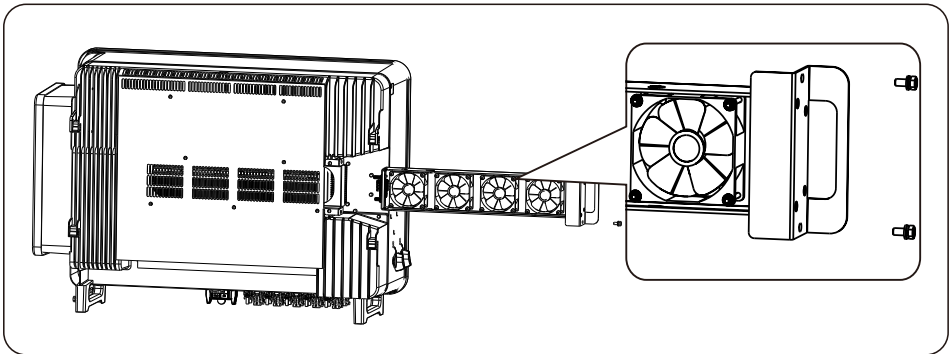
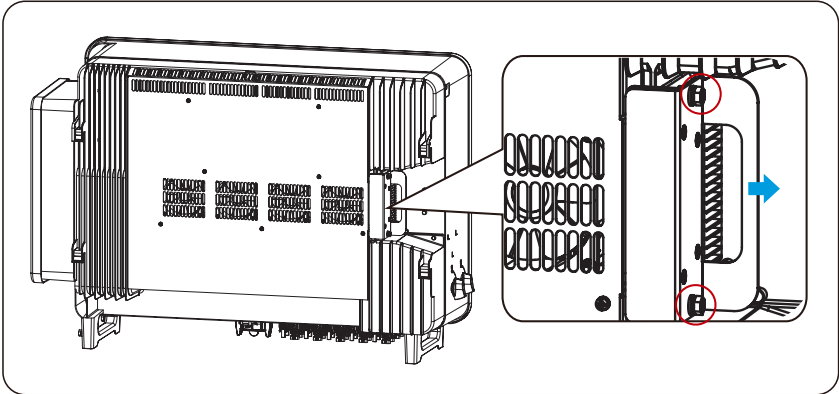

10 Technical Parameters

Technical Data	GW75K-GT-LV-G10
Input	
Max. Input Power (kW)	150
Max. Input Voltage (V)	800
MPPT Operating Voltage Range (V)	180~800
MPPT Voltage Range at Nominal Power (V)	250~650
Start-up Voltage (V)	200
Nominal Input Voltage (V)	370
Max. Input Current per MPPT (A)	42
Max. Short Circuit Current per MPPT (A)	52.5
Max. Backfeed Current to The Array (A)	0
Number of MPP Trackers	8
Number of Strings per MPPT	2
Output	
Nominal Output Power (kW)	75
Nominal Output Apparent Power (kVA)	75
Max. AC Active Power (kW) ^{*3}	75 ^{*6}
Max. AC Apparent Power (kVA) ^{*3}	75
Nominal Power at 40°C (kW)	75
Max. Power at 40°C (Including AC Overload) (kW)	75
Nominal Output Voltage (V)	127/220,3L/N/PE or 3L/PE ^{*7}
Output Voltage Range (V)	176~245
Nominal AC Grid Frequency (Hz)	50/60
AC Grid Frequency Range (Hz)	45~55/55~65
Max. Output Current (A) ^{*5}	196.9
Max. Output Fault Current (Peak and Duration) (A @μs)	364A@5μs
Inrush Current (Peak and Duration) (A/us)	120A@1μs
Nominal Output Current (A)	196.9
Power Factor	~1 (Adjustable from 0.8 leading to 0.8 lagging)

Technical Data	GW75K-GT-LV-G10
Max. Total Harmonic Distortion	<3%
Maximum Output Overcurrent Protection (A)	340
Efficiency	
Max. Efficiency	98.80%
European Efficiency	98.30%
Protection	
PV String Current Monitoring	Integrated
PV Insulation Resistance Detection	Integrated
Residual Current Monitoring	Integrated
PV Reverse Polarity Protection	Integrated
Anti-islanding Protection	Integrated
AC Overcurrent Protection	Integrated
AC Short Circuit Protection	Integrated
AC Overvoltage Protection	Integrated
DC Switch	Integrated
DC Surge Protection	Type II
AC Surge Protection	Type II
AFCI	Optional ^{RS}
Rapid Shutdown	Optional
Remote Shutdown	Integrated
PID Recovery	Optional
Power Supply at Night	Optional
I-V Curve Scan	Optional
I-V Curve Diagnosis	Optional
General Data	
Operating Temperature Range (°C)	-30 ~ +60
Storage Temperature (°C)	-40 ~ +70
Operating Environment	Outdoor
Relative Humidity	0 ~ 100%
Max. Operating Altitude (m)	4000
Cooling Method	Smart Fan Cooling

Technical Data	GW75K-GT-LV-G10
User Interface	LED, LCD (Optional) ,WLAN+APP
Communication	RS485, WiFi+LAN
Communication Protocols	Modbus-RTU (SunSpec Compliant)
Weight (kg)	88
Dimension (W×H×D mm)	930 x 650 x 300
Noise Emission (dB)	<70
Topology	Non-isolated
Self-consumption at Night (W)	<1
Ingress Protection Rating	IP66
Anti-corrosion Class	C4,C5 (Optional)
DC Connector	MC4(4~6mm ²)
AC Connector	OT/DT terminal (Max. 240mm ²)
Environmental Category	4K4H
Pollution Degree	III
Overvoltage Category	DCII / ACIII
Protective Class	I
The Decisive Voltage Class (DVC)	PV:C AC:C com:A
Active Anti-islanding Method	AFDPF + AQDPF
Country of Manufacture	China

Technical Data	GW100K -GT	GW110K -GT	GW125K -GT
Input(DC)			
Max.Input Power (kW)	150	165	187.5
Max.Input Voltage(V)	1100	1100	1100
MPPT Operating Voltage Range (V)	180~1000 ⁹		
MPPT Voltage Range at Nominal Power (V)	500~850		
Start-up Voltage (V)	200		
Nominal Input Voltage (V)	600		
Max. Input Current per MPPT (A)	42		
Max. Short Circuit Current per MPPT (A)	52.5		
Max.Backfeed Current to The Array(A)	0		
Number of MPP Trackers	8	10	10
Number of Strings per MPPT	2		
Output(AC)			
Nominal Output Power (kW)	100 ^{*1}	110	125
Nominal Output Apparent Power (kVA)	100 ^{*1}	110	125
Max. AC Active Power (kW) ^{*3}	110 ^{*1}	121 ^{*4}	137.5 ^{*2}
Max. AC Apparent Power (kVA) ^{*3}	110 ^{*1}	121 ^{*4}	137.5 ^{*2}
Nominal Power at 40°C(kW)	100	110	125
Max Power at 40°C (including AC overload) (kW)	100	110	125
Nominal Output Voltage (V)	220/380, 230/400, 3L/N/PE or 3L/PE		
Output Voltage Range (V)	304~460		
Nominal AC Grid Frequency (Hz)	50/60		
AC Grid Frequency Range (Hz)	45~55/55~65		
Max. Output Current (A) ^{*5}	167.1	183.4	199.4
Max. Output Fault Current (Peak and Duration) (A)	364A@5μs		
Inrush Current (Peak and Duration) (A)	120A@1μs		
Nominal Output Current (A)	152.0 @380V 145.0 @400V	167.1 @380V 159.5 @400V	189.9 @380V 181.2 @400V
Power Factor	~1 (Adjustable from 0.8 leading to 0.8 lagging)		
Max. Total Harmonic Distortion	<3%		

Technical Data	GW100K -GT	GW110K -GT	GW125K -GT
Maximum Output Overcurrent Protection (A)	340		
Efficiency			
Max. Efficiency	98.8%	98.8%	99.0%
European Efficiency	98.4%	98.4%	98.5%
CEC Efficiency	98.3%	98.3%	98.4%
Protection			
PV String Current Monitoring	Integrated		
PV Insulation Resistance Detection	Integrated		
Residual Current Monitoring	Integrated		
PV Reverse Polarity Protection	Integrated		
Anti-islanding Protection	Integrated		
AC Overcurrent Protection	Integrated		
AC Short Circuit Protection	Integrated		
AC Overvoltage Protection	Integrated		
DC Switch	Integrated		
DC Surge Protection	Type II or Type I + II (Optional)		
AC Surge Protection	Type II		
AFCI	Optional		
Emergency Power Off	Optional		
Rapid Shutdown	Optional		
Remote Shutdown	Optional		
PID Recovery	Optional		
Reactive Power Compensation at Night	Optional		
Power Supply at Night	Optional		
I-V Curve Scan	Optional		
I-V Curve Diagnosis	Optional		
General Data			
Operating Temperature Range (°C)	-30 ~ +60		
Storage Temperature (°C)	-40 ~ +70		
Operating Environment	Outdoor		

Technical Data	GW100K-GT	GW110K-GT	GW125K-GT
Relative Humidity	0 ~ 100%		
Max. Operating Altitude (m)	4000		
Cooling Method	Smart Fan Cooling		
User Interface	LED, LCD (Optional) ,WLAN+APP		
Communication	RS485, WiFi or 4G or PLC(Optional)		
Communication Protocols	Modbus-RTU (SunSpec Compliant)		
Weight (Kg)	85	88	88
Dimension (W×H×Dmm)	930 x 650 x 300		
Noise Emission (dB)	<70		
Topology	Non-isolated		
Self-consumption at Night (W)	<2		
Ingress Protection Rating	IP66		
Anti-corrosion Class	C4, C5 (Optional)		
DC Connector	MC4 (4~6mm ²)		
AC Connector	OT/DT terminal (Max. 240mm ²)		
Environmental Category	4K4H		
Pollution Degree	PD 3(External), PD 2(Internal)		
Overvoltage Category	DCII / ACIII		
Protective class	I		
The Decisive Voltage Class (DVC)	PV: C AC: C com: A		
Active Anti-islanding Method	AFDPF + AQDPF		
Country of Manufacture	China		

*1: For Australia is 99.99kW/KVA

*2: For VDE4105 Max. AC Active Power(kW) and Max. AC Apparent Power(kVA) :GW125K-GT is 134.9

*3: For Chile and Brazil Max AC Active Power (kW) and Max. AC Apparent Power(kVA): GW100K-GT is 100; GW110K-GT is 110; GW125K-GT is 125.

*4: For Australia is 110kW/kVA

*5: For Australia Max. Output Current (A): GW100K-GT is 145; GW110K-GT is 159.5.

*6: For Colombia Max.AC Active Power (kW) : GW75K-GT-LV-G10 is 70.9@208V.

*7: For Colombia Nominal Output Voltage (V) : GW75K-GT-LV-G10 is 120/208, 3L/N/PE or 3L/PE.

*8: For Brazil and Colombia is Integrated.

*9: When the input voltage is between 1000V and 1100V, the inverter enters the waiting mode. When the voltage returns to 180V to 1000V, the inverter will resume normal operation.

11 Term Explanation

Overvoltage category definition

Category I: Applies to equipment connected to a circuit where measures have been taken to reduce transient overvoltage to a low level.

Category II: Applies to equipment not permanently connected to the installation. Examples are appliances, portables tools and other plug-connected equipment.

Category III: Applies to a fixed equipment downstream, including the main distribution board. Examples are switchgear and other equipment in an industrial installation.

Category IV: Applies to equipment permanently connected at the origin of an installation (upstream of the main distribution board). Examples are electricity meters, primary over-current protection equipment and other equipment connected directly to outdoor open lines.

Moisture location category definition

Parameters	Level		
	3K3	4K2	4K4H
Moisture Parameters	0 - +40°C	-33 - +40°C	-33 - +40°C
Temperature Range	5% - 85%	15% - 100%	4% - 100%

Environment category definition

Outdoor: Ambient Temperature: -25~+60°C, applied to Pollution Degree 3 environment.

Indoor Unconditioned: Ambient Temperature: -25~+40°C, applied to Pollution Degree 3 environment.

Indoor conditioned: Ambient Temperature: 0~+40°C, applied to Pollution Degree 2

environment. Outdoor: Ambient Temperature: 0~+40°C, applied to Pollution Degree 2 environment.

Pollution degree definition

Pollution Degree I: No pollution or only dry, non-conductive pollution occurs. The pollution has no influence.

Pollution Degree II: Normally only non-conductive pollution occurs. Occasionally, however, a temporary conductivity caused by condensation must be expected.

Pollution Degree III: Conductive pollution occurs, or dry, non-conductive pollution occurs, which becomes conductive due to condensation, which is expected.

Pollution Degree IV: Persistent conductive pollution occurs, for example, the pollution caused by conductive dust, rain or snow.



GoodWe Website

GoodWe Technologies Co., Ltd.

 No. 90 Zijin Rd., New District, Suzhou, 215011, China

 www.goodwe.com

 service@goodwe.com



Local Contacts