

# Power Conversion System

**GW100K-PCS-N-G10, GW125K-PCS-N-G10**

**GW100K-PCS-N-G11, GW125K-PCS-N-G11**

**(GW500K-STS-PCS-G10)**

**User Manual**

V1.5 2026.03.10

---

**GOODWE**

Copyright Statement:

**Copyright © GoodWe Technologies Co., Ltd. 2026. All rights reserved.**

No part of this manual can be reproduced or transmitted to the public platform in any form or by any means without the prior written authorization of GoodWe Technologies Co., Ltd..

**Trademark**

**GOODWE** and other GOODWE trademarks are trademarks of GoodWe Technologies Co.,Ltd. All other trademarks or registered trademarks mentioned in this manual are owned by GoodWe Technologies Co., Ltd.

**NOTICE**

The information in this user manual is subject to change due to product updates or other reasons. This guide cannot replace the product labels otherwise specified. All descriptions here are for guidance only.

## Content

1 About This Manual .....	3
1.1 Overview .....	3
1.2 Applicable Model .....	3
1.3 Symbol Definition .....	3
2 Safety Precautions .....	4
2.1 General Safety .....	5
2.2 Battery Safety .....	5
2.3 PCS Safety .....	6
2.4 Personnel Requirements .....	7
2.5 EU Declaration of Conformity .....	8
3 Product Introduction .....	8
3.1 Product Overview .....	8
3.2 Application scenario .....	9
3.3 Circuit Block Diagram .....	13
3.4 Appearance Description .....	14
3.4.1 Appearance and Port Introduction .....	14
3.4.2 Size .....	15
3.4.3 Equipment operation mode .....	16
3.4.4 Indicator Description .....	18
3.4.5 Features .....	19
4 Check and Storage .....	20
4.1 Check Before Receiving .....	20
4.2 Deliverables .....	20
4.3 Storage .....	21

5 Installation .....	22
5.1 Installation Requirements .....	22
5.2 PCS Installation .....	27
5.2.1 Moving the PCS .....	27
5.2.2 PCS Installation .....	27
6 Electrical Connection .....	30
6.1 Cable requirements .....	32
6.3 Connecting the PE cable .....	34
6.4 Connection Power Cable .....	35
6.5 Connecting the Communication cable .....	38
7 Equipment Commissioning .....	43
7.1 Check Items before Power ON .....	43
7.2 Power On .....	43
8 System Commissioning .....	44
8.1 Commissioning via a Host Computer .....	44
8.2 Device Parameter Configuration via SolarGo .....	44
9 Maintenance .....	45
9.1 PCS Power Off .....	45
9.2 Removing the PCS .....	47
9.3 Disposing of the PCS .....	47
9.4 Troubleshooting .....	47
9.5 Routine Maintenance .....	57
10 Technical Parameter .....	60
PCS .....	60
STS (GW500K-ST5-PCS-G10) .....	65

# 1 About This Manual

## 1.1 Overview

This document describes the product information, installation, electrical connection, troubleshooting, and maintenance of the Power Conversion System (PCS). Read through this manual before installing and operating the products to understand product safety information and familiarize yourself with functions and features of the product. This manual is subject to update without notice. For more product details and latest documents, visit <https://en.goodwe.com/>.

## 1.2 Applicable Model

This document applies to the PCSs of the following models.

Product model	Nominal output power	Nominal output voltage	Description
GW100K-PCS-N-G10	100kW	400/380V, 3L/N/PE	Integrating PDU (Power Distribution Unit), and apply to Chinese and overseas market
GW125K-PCS-N-G10	125kW		
GW100K-PCS-N-G11	100kW		Applying to Chinese and overseas market
GW125K-PCS-N-G11	125kW		

## 1.3 Symbol Definition

Different levels of warning messages in this manual are defined as follows:

<b>DANGER</b>
Indicates a high-level hazard that, if not avoided, will result in death or serious injury.
<b>WARNING</b>

Indicates a medium-level hazard that, if not avoided, could result in death or serious injury.

**CAUTION**

Indicates a low-level hazard that, if not avoided, could result in minor or moderate injury.

**NOTICE**

Highlight and supplement the texts. Or some skills and methods to solve product-related problems to save time.

## 2 Safety Precautions

The safety precautions information contained in this document must always be followed when operating the equipment.

**WARNING**

The PCSs are designed and tested strictly complying with related safety rules. Read and follow all the safety instructions and cautions before any operations. Improper operation might cause personal injury or property damage as the inverters are electrical equipment.

## 2.1 General Safety

### NOTICE

- The information in this document is subject to change due to product updates or other reasons. This document cannot replace the product labels or the safety precautions unless otherwise specified. All descriptions in the manual are for guidance only.
- Before installations, read through the user manual to learn about the product and the precautions.
- All operations should be performed by trained and knowledgeable technicians who are familiar with local standards and safety regulations.
- Use insulating tools and wear personal protective equipment (PPE) when operating the equipment to ensure personal safety. Wear anti-static gloves, wrist strips, and cloths when touching electronic devices to protect the equipment from damage.
- Installation, operation and maintenance must be carried out in accordance with the procedures in the manual. Unauthorized modifications, additions, or alterations to the equipment and unauthorized change to the installation sequence are prohibited.
- Arc welding, cutting, or similar operations on the equipment are prohibited without prior evaluation by the manufacturer.
- Please use the correct tools and use them properly.
- Do not block or cover the vents, cooling system during equipment operation to prevent high-temperature damage or fire hazards.
- It is strictly prohibited to operate or installed the equipment beyond the specified technical parameters as it may compromise both performance and safety.
- Unauthorized dismantling or modification may damage the equipment, and the damage is not covered under the warranty.
- Strictly follow the installation, operation, and configuration instructions in this manual or the user manual. The manufacturer shall not be liable for equipment damage or personal injury if you do not follow the instructions. For more warranty details, please visit <https://www.goodwe.com/warrantyrelated.html>.

## 2.2 Battery Safety

### DANGER

There is a lethal high voltage between the positive and negative terminals of the Battery.

- When performing equipment maintenance, ensure that the connection between the PCS and the Battery is completely disconnected.
- Ensure that accidental re-connection will not occur when disconnecting breakers.



**WARNING**





- Please confirm with the PCS manufacturer regarding the power, BMS communication point list, etc. For battery used with the PCS.
- Use a multimeter with a 1000V range to measure the positive and negative poles of the DC cable to ensure correct polarity; and ensure that the voltage is within the allowable range.

## 2.3 PCS Safety

**DANGER**

- Electric shock
- Only intact and closed enclosure can protection personnel and property safety. Do not open the enclosure when the PCS is operating or energized. Otherwise the equipment manufacturer will not be held liable for potential damage.
- After the PCS is installed, the labels and warning signs on the enclosure must remain clearly visible. Obscuring, altering, or damaging labels are prohibited.

No.	symbol	meaning
1		High voltage DANGER. High voltage is present during equipment operation. Ensure the equipment is POWER OFF before performing any operations.
2		Delayed discharge. After power off the equipment, please wait for 5 minutes until the equipment is completely Discharge.
3		Before operating the equipment, please read the product manual in detail.

4		Potential DANGER may exist after equipment operation. Take necessary precautions during operation.
5		The equipment surface is at high temperature. Do not touch during operation to avoid burns.
6		grounding point.
7		CE marking.
8		The equipment must not be disposed of as household waste. Please handle the equipment in accordance with local laws and regulations or return it to the manufacturer.

## 2.4 Personnel Requirements

### NOTICE

To ensure the safety, compliance, and efficiency throughout the transportation, installation, wiring, operation, and maintenance of the equipment, the work must be carried out by professionals or qualified personnel.

1. Professionals or qualified personnel include:
  - Personnel who have mastered the equipment's working principles, system structure, and knowledge of relevant risks and hazards, and have received professional operation training or possess rich practical experience.
  - Personnel who have received relevant technical and safety training, have certain operational experience, can be aware of potential dangers that specific operations may pose to themselves, and are able to take protective measures to minimize risks to themselves and others.
  - Qualified electrical technicians who meet the regulatory requirements of the country/region where they are located.
  - Personnel who hold a degree in electrical engineering/an advanced diploma in an electrical discipline or equivalent qualification/a professional qualification in the electrical field, and have at least 2/3/4 years of experience in testing and supervising in accordance with electrical equipment safety standards.
2. Personnel engaged in special tasks such as electrical operations, working at heights, and operation of special equipment must hold valid qualification certificates as required by the location of the equipment.

3. Operation of medium-voltage equipment must be performed by certified high-voltage electricians.
4. Replacement of the equipment and its components is only permitted to be carried out by authorized personnel.

## 2.5 EU Declaration of Conformity

Equipment with Wireless Communication Modules marketable in Europe complies with the following directives:

- Restrictions of Hazardous Substances Directive 2011/65/EU and (EU) 2015/863 (RoHS)
- Waste Electrical and Electronic Equipment 2012/19/EU
- Registration, Evaluation, Authorization and Restriction of Chemicals (EC) No 1907/2006 (REACH)

For more EU Declaration of Conformity, please visit the official website: <https://en.goodwe.com>.

## 3 Product Introduction

### 3.1 Product Overview

The main function of the power conversion system (PCS) is energy conversion between the energy storage unit (such as battery) and the AC-side utility grid or equipment. The PCS has both rectification and inversion capabilities. Rectification refers to the PCS converting three-phase AC power into DC power and storing the energy in battery. Inversion refers to the PCS converting the DC energy from battery into three-phase AC power then fed into the utility grid or used by the load.

The PCS must be used together with the GW500K-ST5-PCS-G10.

#### Model Description

This document applies to the following model PCS:

GW100K-PCS-N-G10, GW125K-PCS-N-G10, GW100K-PCS-N-G11, GW125K-PCS-N-G11

#### Model Meaning

**GW100K-PCS-N-G10**

1      2      3      4      5

BTH10DSC0005

No.	Meaning	Description
1	Brand code	GW: GoodWe
2	Nominal power	100K: Nominal power is 100kW 125K: Nominal power is 125kW
3	Series code	PCS: PCS Series
4	Special Characteristic Code	N: Three-phase four-wire
5	Version code	G10/G11: First-generation products

### Supported Grid type

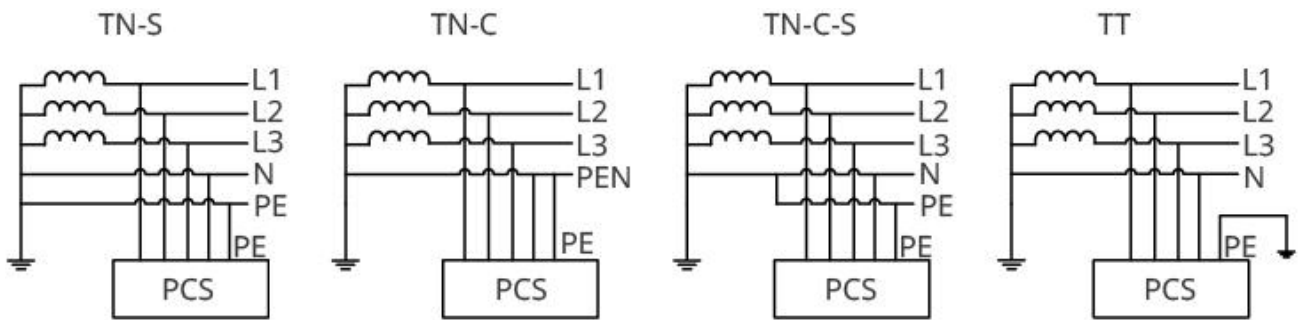

TNNET0014

### NOTICE

The equipment does not support direct connection to an IT-system grid. If the customer requires connection to an IT-system grid, an externally provided isolation transformer can be used for this purpose. The specific wiring method must comply with local regulations.

## 3.2 Application scenario

The PCS converts the DC power from battery into three-phase AC power. It can also transform AC power into DC power acceptable to battery to charge batteries.

The PCS is a multi-mode inverter, and the grid-tied / off-grid mode switching is controlled by EMS commands.

### On-grid mode:

Operating in P/Q mode, the PCS can respond to third-party EMS commands to meet various C&I energy storage applications such as peak-valley tariff arbitrage, transformer area expansion, and demand-side response, etc.. It also supports renewable energy (such as PV) storage applications, smoothing renewable energy generation and assisting in renewable energy grid integration.

**Off-grid mode:**

Operating in V/F mode, the PCS features off-grid energy discharging and charging, and can collaborate with a third-party EMS to meet various off-grid and microgrid applications, such as PV-storage microgrids, emergency power supply, mobile energy storage vehicles, PV-storage-diesel microgrids, and storage-diesel microgrids.

**Type I**

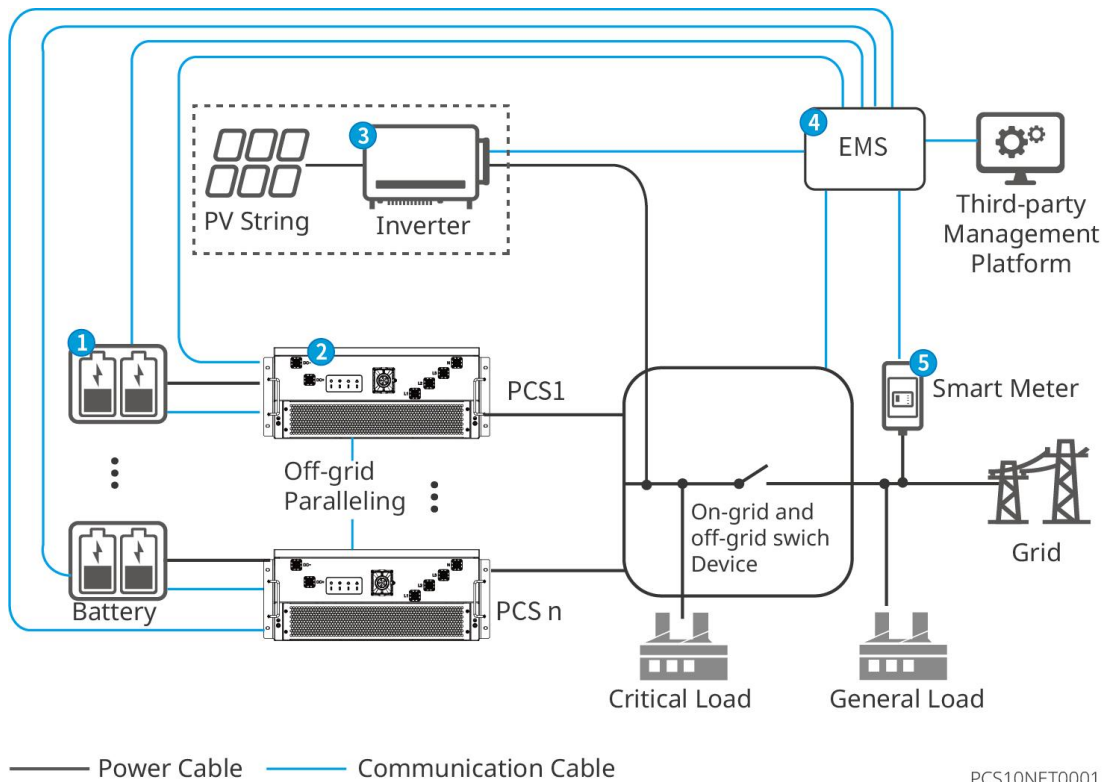

## Type II

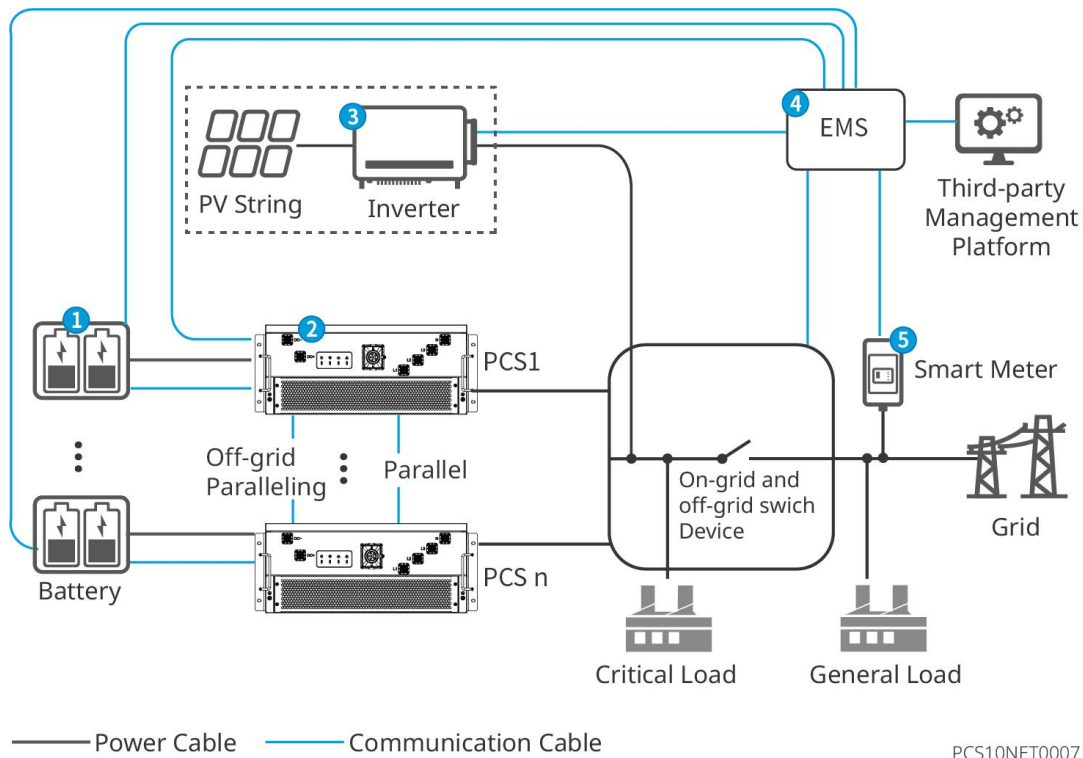

No.	Component	Description
1	Battery system	Releasing and storing electrical energy. The PCS can communicate with the battery BMS via CAN or RS485.
2	PCS	<ul style="list-style-type: none"> <li>The PCS operates in P/Q mode for on-grid operation. It is responsible for energy conversion between battery and utility grid, supporting active and reactive power control to implement EMS energy dispatch strategies.</li> <li>The PCS operates in V/F mode for off-grid operation. It outputs three-phase AC power to continuously power the load, supporting the connection of PV inverter and other devices for battery charging.</li> </ul>
3	Inverter	Converting DC power from PV into AC power. The Inverter must be compatible with EMS and can be selected from GoodWe or third-party brands.

No.	Component	Description
4	EMS (SEC3000C)	Responsible for energy dispatch and monitoring of the entire system. The SEC3000C integrates a GM330 meter, enabling coordinated operation to implement grid- connected power limitation. Supported protocols: Modbus RTU, Modbus TCP.
5	Smart Meter	It assists the EMS to control the power fed into utility grid to achieve the export power limit function.

### 3.3 Circuit Block Diagram

The N and PE conductors shall be bonded together within the distribution box.

#### NOTICE

For neutral integrity, the neutrals on the grid-tied and off-grid sides must be bonded; otherwise, off-grid operation will fail.

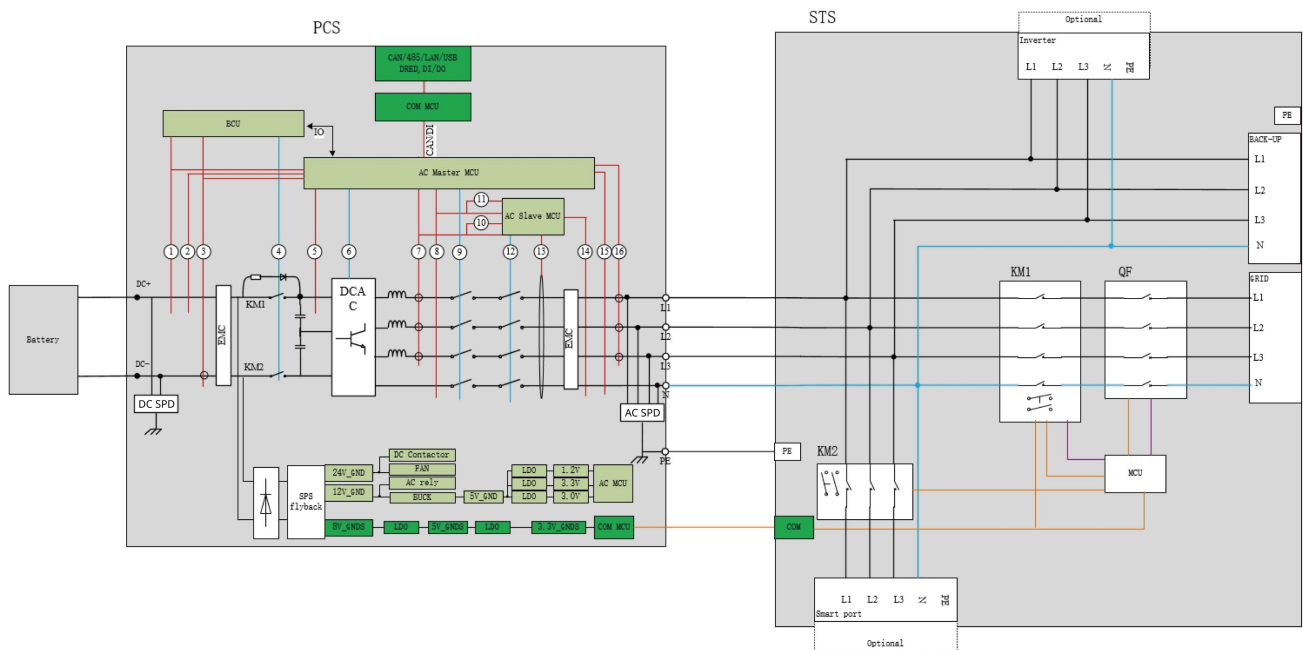

### System Wiring Diagram

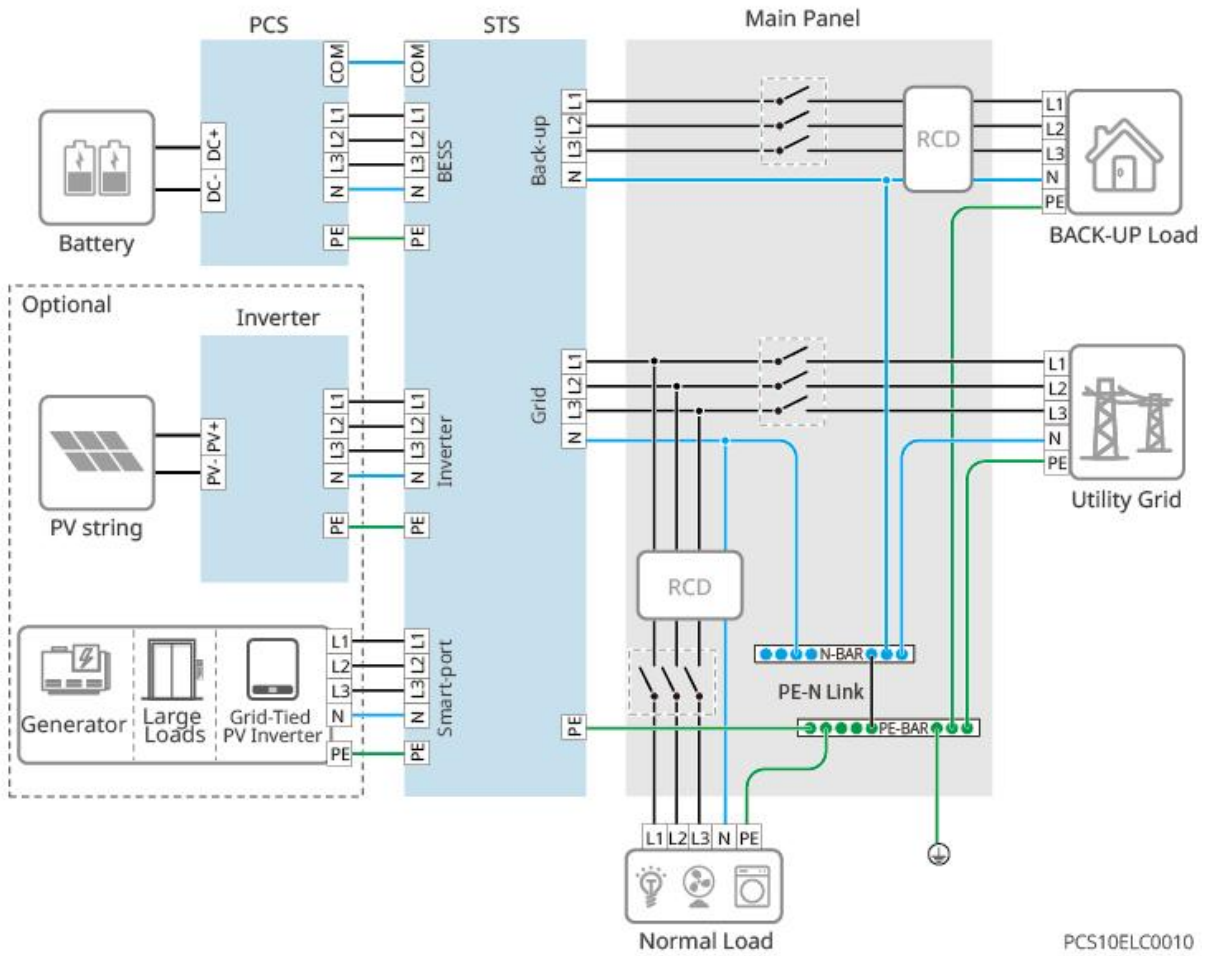

### 3.4 Appearance Description

#### 3.4.1 Appearance and Port Introduction

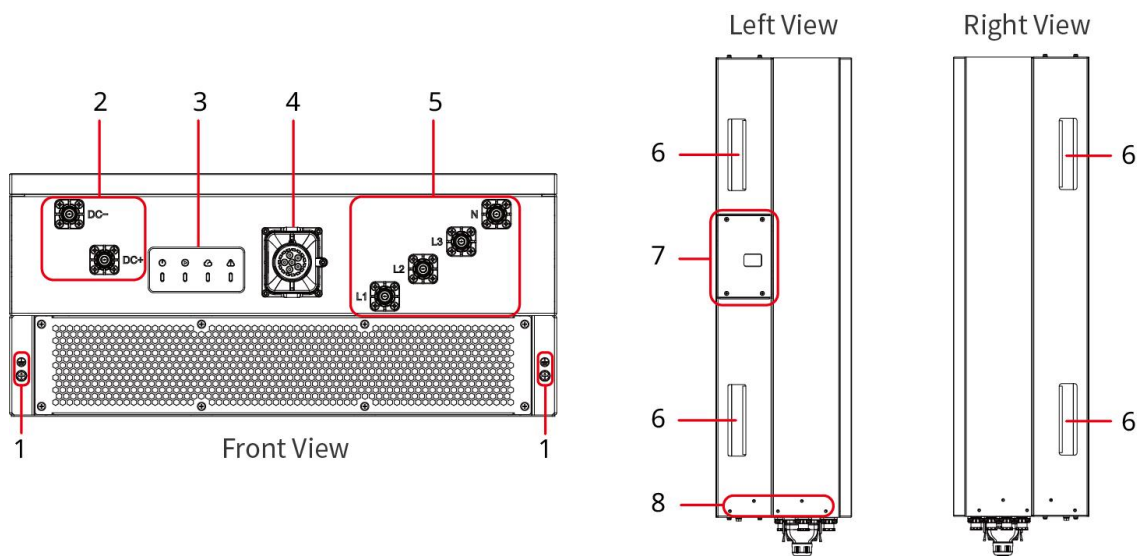

NO.	Name	Function
1	Enclosure grounding port	For the PE cable connecting
2	Battery wiring port	For the battery power cable connecting
3	Indicator	Indicating the working status of the PCS.
4	Communication connection port	External communication interface
5	AC wiring port	For AC cable connecting
6	Lifting Handle	For transporting PCS
7	Fan maintenance port	Removable for fan maintenance
8	Mounting lug hole	For the drawer-type mounting ear installation

### 3.4.2 Size

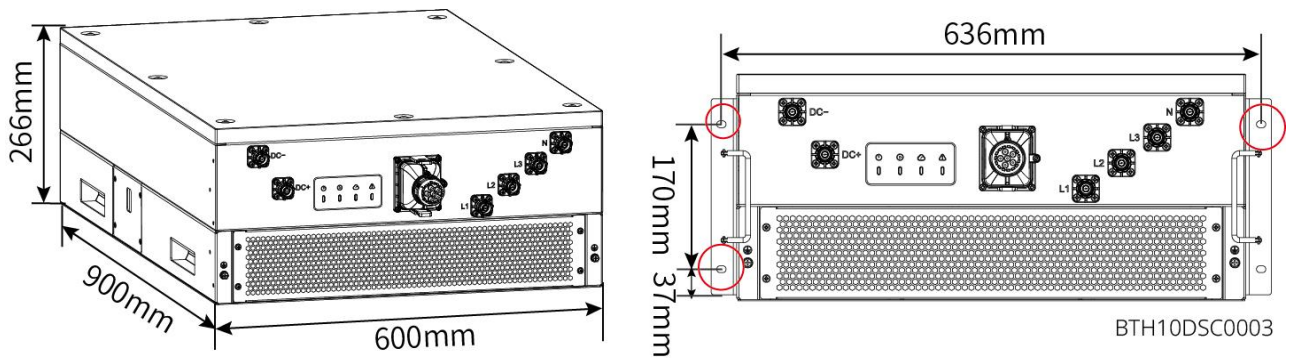

### 3.4.3 Equipment operation mode

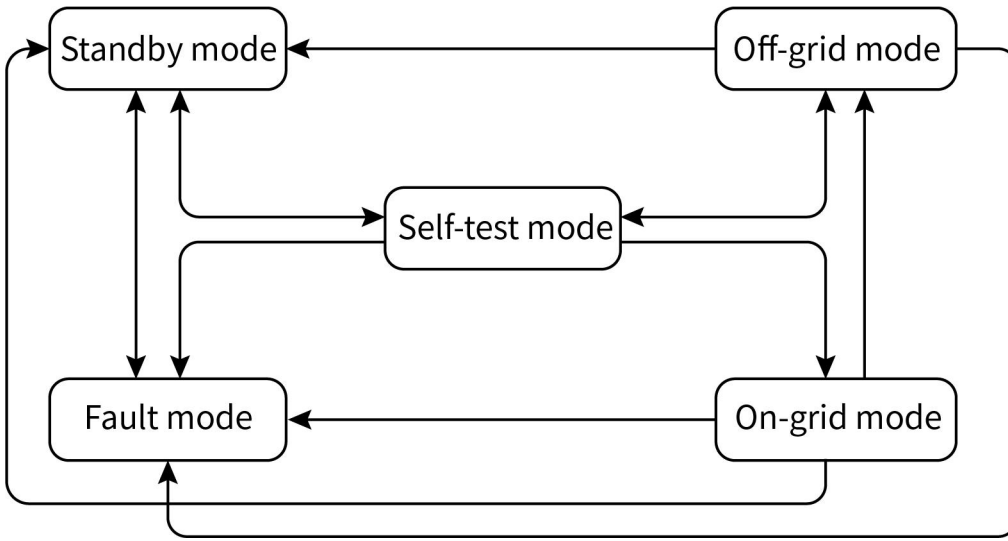

No.	Name	Description
1	Standby mode	<p>Standby stage after the machine is powered on.</p> <ul style="list-style-type: none"> <li>When the conditions are met, the PCS enters the self-test mode.</li> <li>If there is fault, the PCS enters fault mode.</li> </ul>
2	Self-test mode	<p>The machine continuously performs self-check and initialization before startup.</p> <ul style="list-style-type: none"> <li>If the conditions are met, it proceeds to on-grid mode, and the machine initiates on-grid operation.</li> <li>If no utility grid is detected, the system enters off-grid mode and operates off-grid; if the PCS does not support off-grid functionality, it enters standby mode.</li> <li>If the self-check fails, it will enter fault mode.</li> </ul>
3	On-grid mode	<p>The machine is operating normally.</p> <ul style="list-style-type: none"> <li>If no utility grid is detected, the system will enter the off-grid operation mode.</li> <li>If a fault is detected, the system will enter fault mode.</li> </ul>

No.	Name	Description
		<ul style="list-style-type: none"> <li>● If it is detected that the utility grid condition does not meet the on-grid requirements and the off-grid output is not enabled, it will enter standby mode.</li> </ul>
4	Off-grid mode* <sup>1</sup>	<p>When the grid is disconnected, the PCS switches to off-grid mode and continues to supply power to the load.</p> <ul style="list-style-type: none"> <li>● If a fault is detected, the system will enter fault mode.</li> <li>● If it is detected that the utility grid condition does not meet the on-grid requirement and the off-grid output is not enabled, it will enter standby mode.</li> <li>● If the utility grid condition is detected to meet the on-grid requirements and the off-grid output is enabled, the system will enter the self-test mode.</li> </ul>
5	Fault mode	<p>If fault is detected, the machine enters fault mode. Once fault is cleared, it switches to standby mode.</p>

\*1: The machine is a multi-mode PCS that supports off-grid operation. For grid-connected/off-grid switching, an external switching device is required.

### 3.4.4 Indicator Description

INDICATOR	STATUS	EXPLANATION
		Power ON
		Power OFF
		On-grid
		Waiting or OFF
		Off-grid
		Self-checking
		COMM. ON
		COMM. OFF
		Fault
		Warning
		No Fault

DRM 0	<input checked="" type="checkbox"/>	DRM 1	<input checked="" type="checkbox"/>	DRM 2	<input checked="" type="checkbox"/>
DRM 3	<input checked="" type="checkbox"/>	DRM 4	<input checked="" type="checkbox"/>	DRM 5	<input checked="" type="checkbox"/>
DRM 6	<input checked="" type="checkbox"/>	DRM 7	<input checked="" type="checkbox"/>	DRM 8	<input checked="" type="checkbox"/>

Note: For Australia and New Zealand only  
350-\*\*\*\*\*.\*\*

## 3.4.5 Features

### Power Derating

To ensure the safe operation of the PCS and the compliance with local safety regulations, the PCS will automatically reduce its output power when operating under non-ideal environmental conditions.

The following are factors that may cause power derating. Please try to avoid them during operation.

- Adverse environmental conditions, such as direct sunlight, high temperatures, etc.
- The output power percentage of the PCS has been set.
- Utility grid voltage and frequency variations.
- DC input voltage is too high or too low.

### Three-phase Unbalanced Output

The AC side of the PCS supports three-phase unbalanced output. It allows independent setting of the power magnitude for each phase with each phase setting not exceeding one-third of the maximum power capacity of the unit.







## 4 Check and Storage



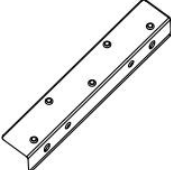

### 4.1 Check Before Receiving

Before signing for the product, please carefully inspect the following:

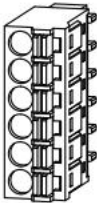
1. Check the outer packaging for any damage, such as deformation, punctures, cracks, or other signs that may indicate potential harm to the equipment inside the box. If damage is found, do not open the packaging and contact your distributor.
2. Check if the PCS model is correct. If it does not match, do not open the packaging and contact your distributor.
3. Check whether the deliverables type and quantity are correct and whether there is any damage to the appearance. If damaged, please contact your distributor or manufacturer.

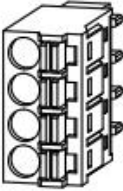
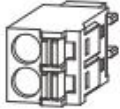
### 4.2 Deliverables

Component	Description	Component	Description
	PCS x 1		DC connector x 2
	AC connector x 4		Drawer-type mounting ears x 2
	Drawer handle x 2		Screw (M4*8) x 14
	Screw (M6*18) x 4		6 pin communication terminal x 2

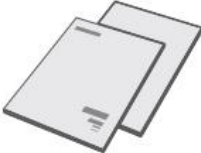
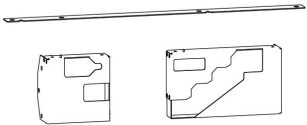
	4 pin communication terminal x 2		2 pin communication terminal x 2
	PIN terminal x 24		Terminal resistor x 1
	Terminal resistor x 1		Product document x1
	Protective cover x 1		

### 4.3 Storage

If the PCS is not to be put into use immediately, please store it according to the following requirements:

1. Ensure that the outer packaging box is not dismantle, and the desiccant inside the box is not missing.
2. Ensure that the storage environment is clean, with an appropriate temperature range, and free from condensation.
3. Ensure that the stack layers, height, and orientation of the PCS comply with the requirements indicated on the packaging box label.
4. Ensure there is no risk of tipping after the PCS is installed.
5. If the PCS has been stored for six months or longer, it must be inspected and confirmed by a professional before it can be put back into use.
6. Store the equipment as per the storage requirements section. Damage caused by failure to meet storage conditions is not covered under warranty.

# 5 Installation

## 5.1 Installation Requirements

### Installation Environment Requirements

1. Equipment must not be installed in flammable, explosive, or corrosive environments.
2. Do not place the equipment near heat sources or open flames, such as fireworks, candles, heaters, or other heat-generating devices as exposure to heat may cause equipment damage or fire hazards.
3. The equipment should be installed in an area away from liquids. It is strictly forbidden to install it under water pipes, air outlets and other locations where condensation water is likely to be generated. It is strictly forbidden to install it under air conditioning outlets, vents, computer room outlet windows and other locations prone to water leakage to prevent liquid from entering the equipment during maintenance and causing equipment failure or short circuit.
4. It is strictly prohibited to place the equipment in environments with dust, smoke, volatile gases, corrosive gases, infrared or other radioactive radiation, organic solvents, or excessive salt content.
5. It is strictly prohibited to operate the equipment in environments with conductive metal dust or magnetic conductive dust.
6. It is strictly prohibited to install the equipment in areas prone to microbial growth such as fungi and mold.
7. The site selection shall comply with local laws, regulations, and relevant standard requirements.
8. Installation location should be kept out of reach of children and avoid Installation in easily accessible locations. The surface of the equipment may become hot during operation to prevent burns.
9. The equipment will emit noise during operation, and Installation location should be kept away from areas highly sensitive to noise, such as residential areas, schools, hospitals, etc. This is to prevent the noise generated by the equipment from causing disturbances to people living in the surrounding environment.
10. The PCS should be protected from exposure to sunlight, rain, snow accumulation, and other Installation conditions. It is recommended to install the PCS in a shaded location. If necessary, a sunshade can be constructed.
11. The Installation space must meet the ventilation and heat dissipation requirements of the equipment as well as the operational space requirements.
12. The equipment ingress protection rating meet indoor and outdoor installation, and the ambient temperature and humidity should be within the appropriate range.

13. The height of the equipment Installation should facilitate operation and maintenance, ensuring that the equipment indicator and all labels are easily visible, and the wiring terminal is easy to operate.
14. The installation altitude should be below the Max. Operating Altitude 4000m.
15. Keep away from strong magnetic fields to avoid electromagnetic interference. If there are radio stations or wireless communication devices below 30MHz near the Installation Location, follow the requirements below to Installation the equipment:
  - Add ferrite cores with multiple turns on the DC input or AC output lines of the PCS, or incorporate low-pass EMI Filter.
  - The distance between the PCS and the wireless electromagnetic interference equipment exceeds 30m.

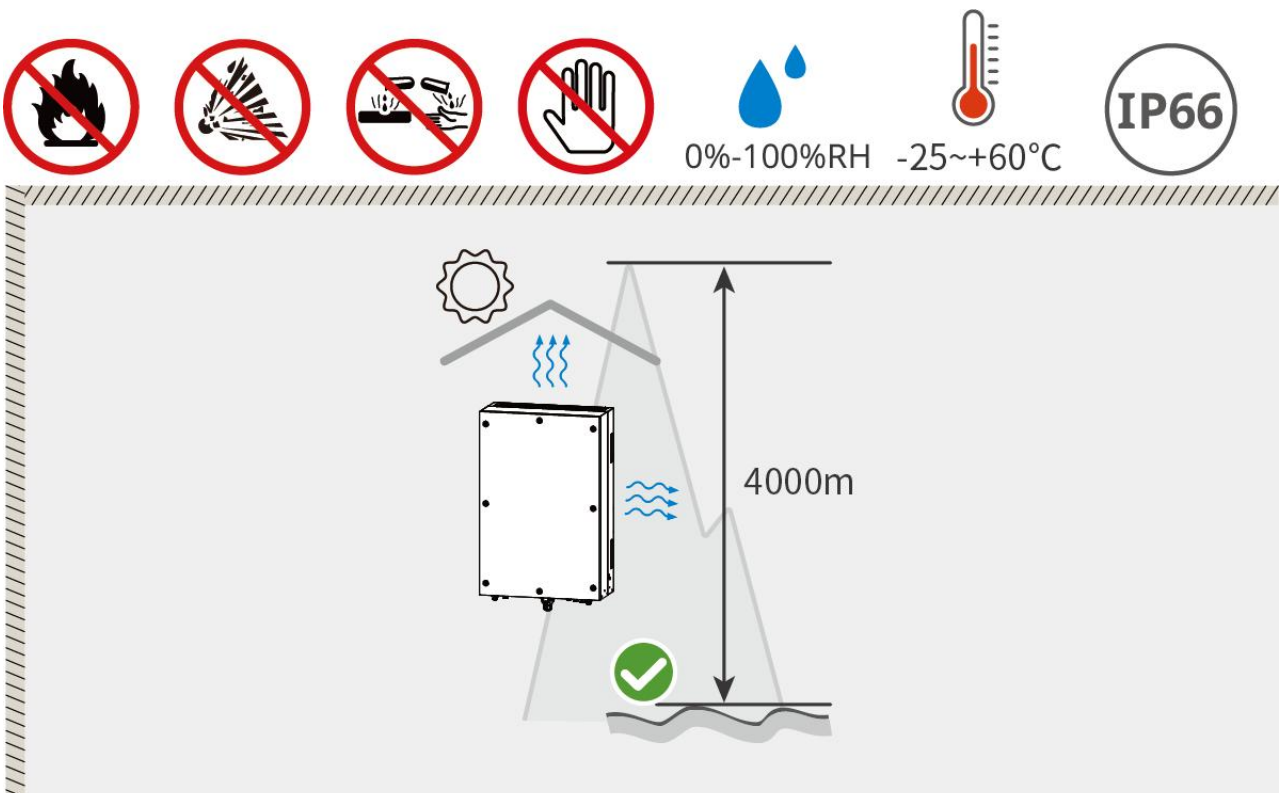

BTH10INT0014

### Installation carrier requirements

- The installation carrier must not be made of flammable materials and must be fire-resistant.
- Please ensure that the installation carrier is sturdy, reliable and capable of bearing the weight of the PCS.

### Installation angle

The PCS can be installed flat or sideways.

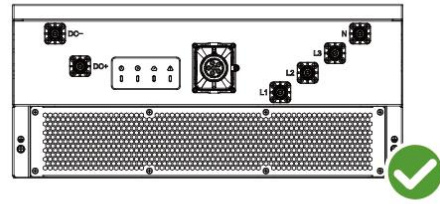
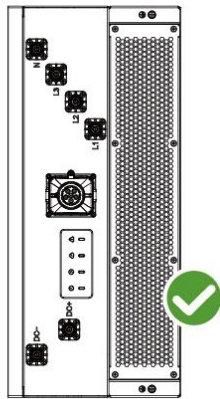
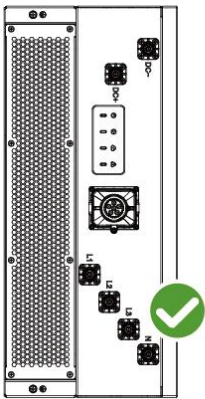

BTH10INT0006

### Installation Space Requirements

#### NOTICE

- When installing the product in an enclosed environment (such as inside a cabinet or enclosure), please ensure adequate ventilation by avoiding obstruction of the air intake and exhaust vents. If necessary, install cooling devices (e.g., cooling fans) to guarantee sufficient airflow. Otherwise, poor ventilation may lead to product overheating.
- The PCS shall be mounted on load-bearing guide rails. Direct stacking on top of the lower-layer PCS is prohibited.

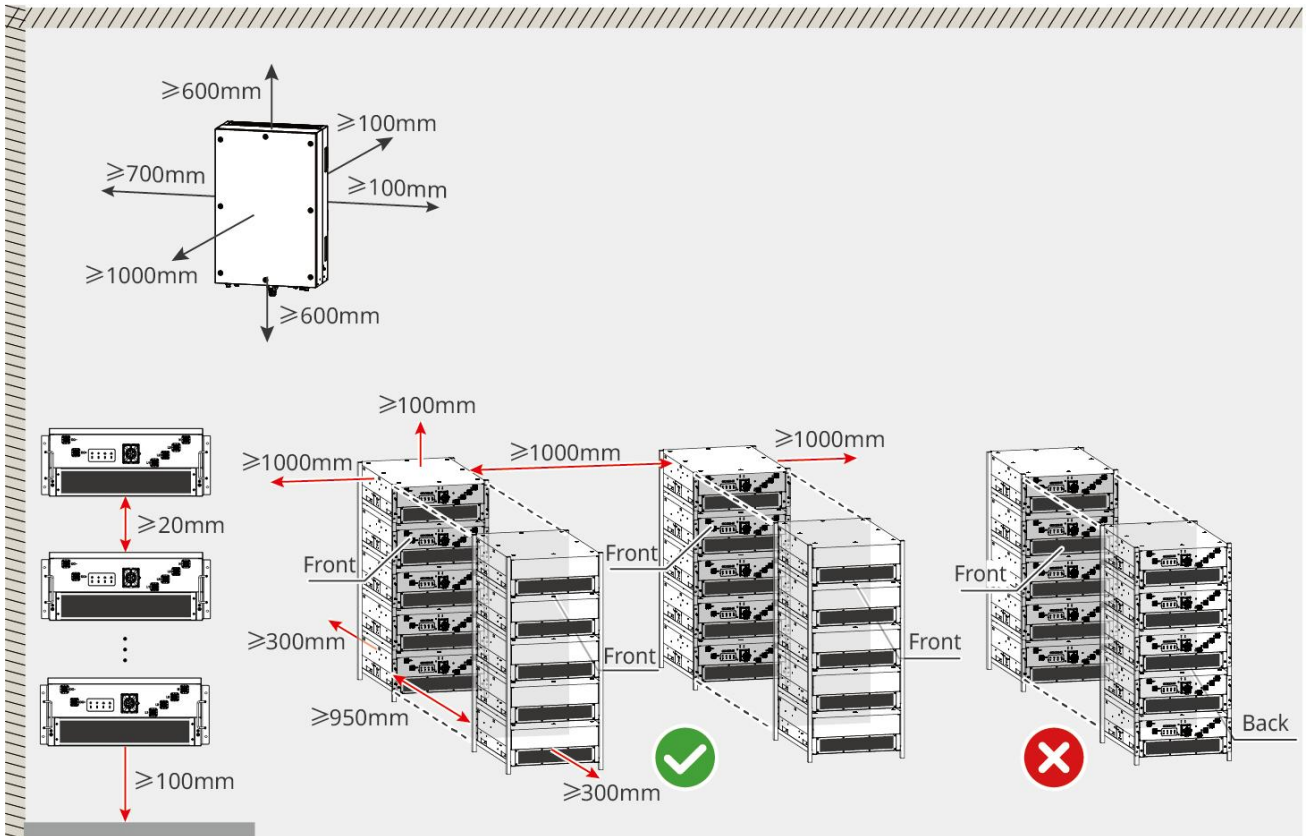

PCS10INT0015

## Installation Tool Requirements

It is recommended to use the following Installation tools. If necessary, other auxiliary tools can be used.

### NOTICE

- Before operating the equipment, carefully inspect all tools to ensure they meet requirements and record them in the log. After the operation, retrieve all tools according to the count to prevent them from being left inside the equipment.
- All tools must be fully prepared and inspected by a professional organization to ensure they are qualified. It is prohibited to use tools with defects, the tools that fail inspection, or beyond the inspection validity period. Tools must be securely fastened and can not be overloaded.

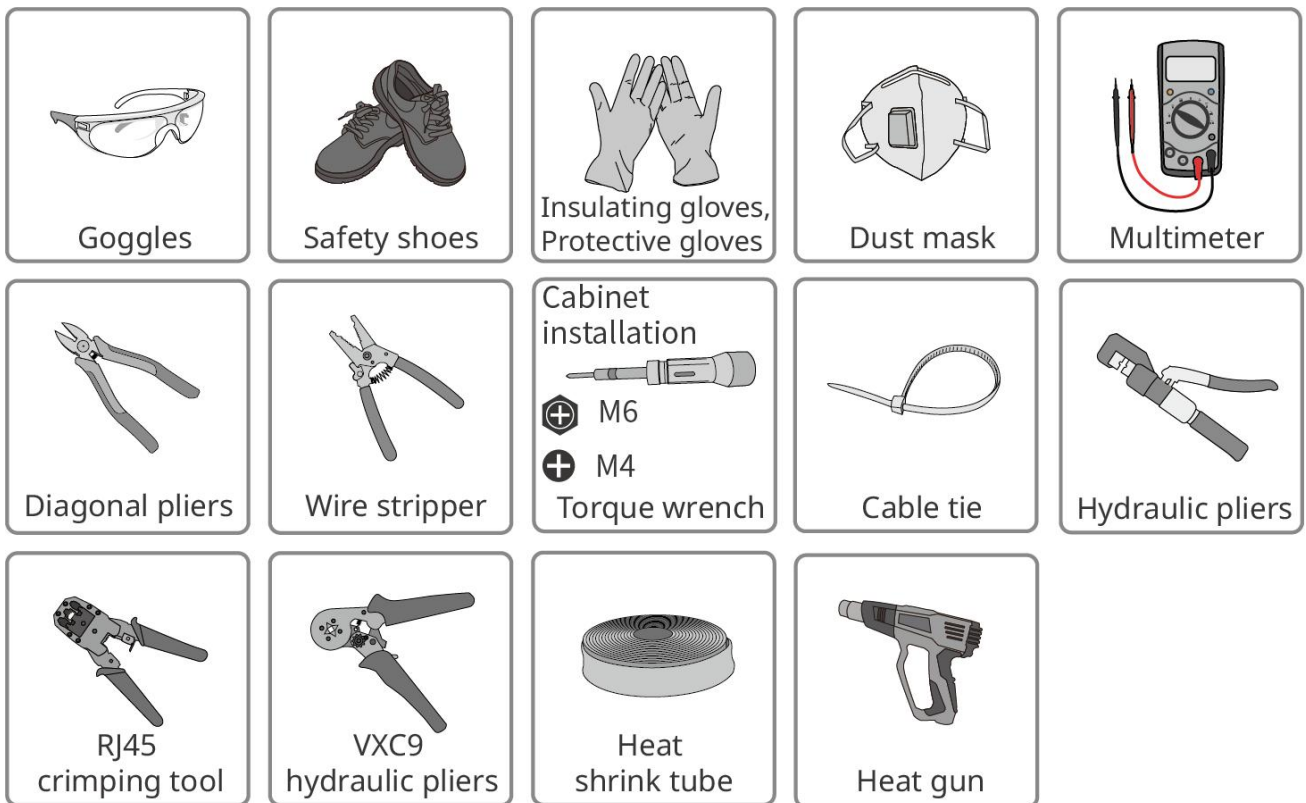

### Heat dissipation requirements

When the PCS is installed in a cabinet, to prevent the hot air from flowing back to the cold air inlet at the PCS outlet, install an air baffle at the outlet, as shown in the figure:

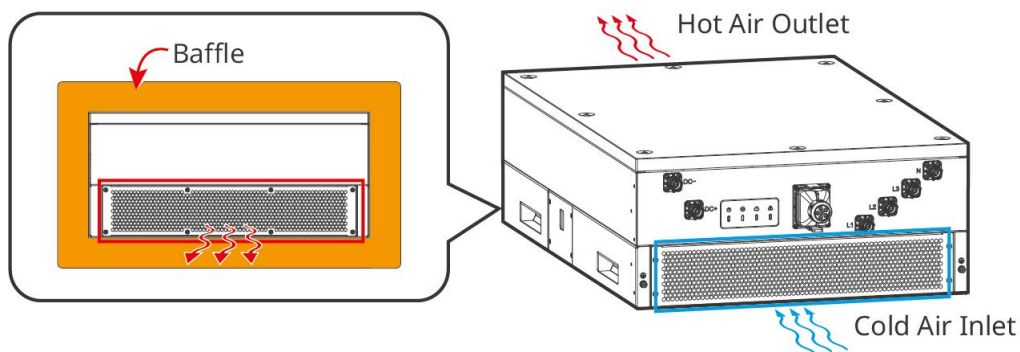

BTH10INT0007

## 5.2 PCS Installation

### 5.2.1 Moving the PCS

#### CAUTION

- Operations such as transportation, turnover, installing and so on must meet the requirements of local laws and regulations.
- During transportation, ensure that the cargo is securely fastened, use appropriate packaging materials, avoid overloading, keep the handling pathways clear, and prevent damage from jolting.
- Any paint scratches that occur during transportation and installation must be promptly repaired, and prolonged exposure of the scratched areas is prohibited.
- Please use the correct tools and master the proper methods of using them.
- Before installation, the PCS must be transported to the installation location. To prevent personal injury or equipment damage during transportation, please NOTICE the following matters:
  1. Please assign appropriate personnel and tools according to the equipment weight to avoid exceeding the manual handling limits and prevent injury from falling equipment.
  2. Please wear safety gloves to avoid injury.
  3. Please ensure the equipment remains balanced during handling to avoid dropping.

### 5.2.2 PCS Installation

#### NOTICE

- The handle is only used for pushing or pulling the PCS and must not be used for bearing weight.
- Ensure the PCS is securely fastened to prevent it from falling or personnel injury.
- Drilling on the equipment is prohibited. Drilling can damage the equipment's sealing, electromagnetic shielding performance, internal components, and cables. Metal shavings generated during drilling may enter the equipment and cause a short circuit on the circuit board.

#### Installation procedure

- **Standalone installation**
  - **Installed vertically**

Step 1: Mark the hole positions on the wall with a marker pen.

Step 2: Install the expansion bolts.

Step 3: Fix the backplate to the wall using the expansion bolts.

Step 4: Install the cable protection cover.

Step 5: Attach the hooks to the PCS.

Step 6: Hanging the PCS onto the backplate.

Step 7: Tighten the PCS fixing screws.

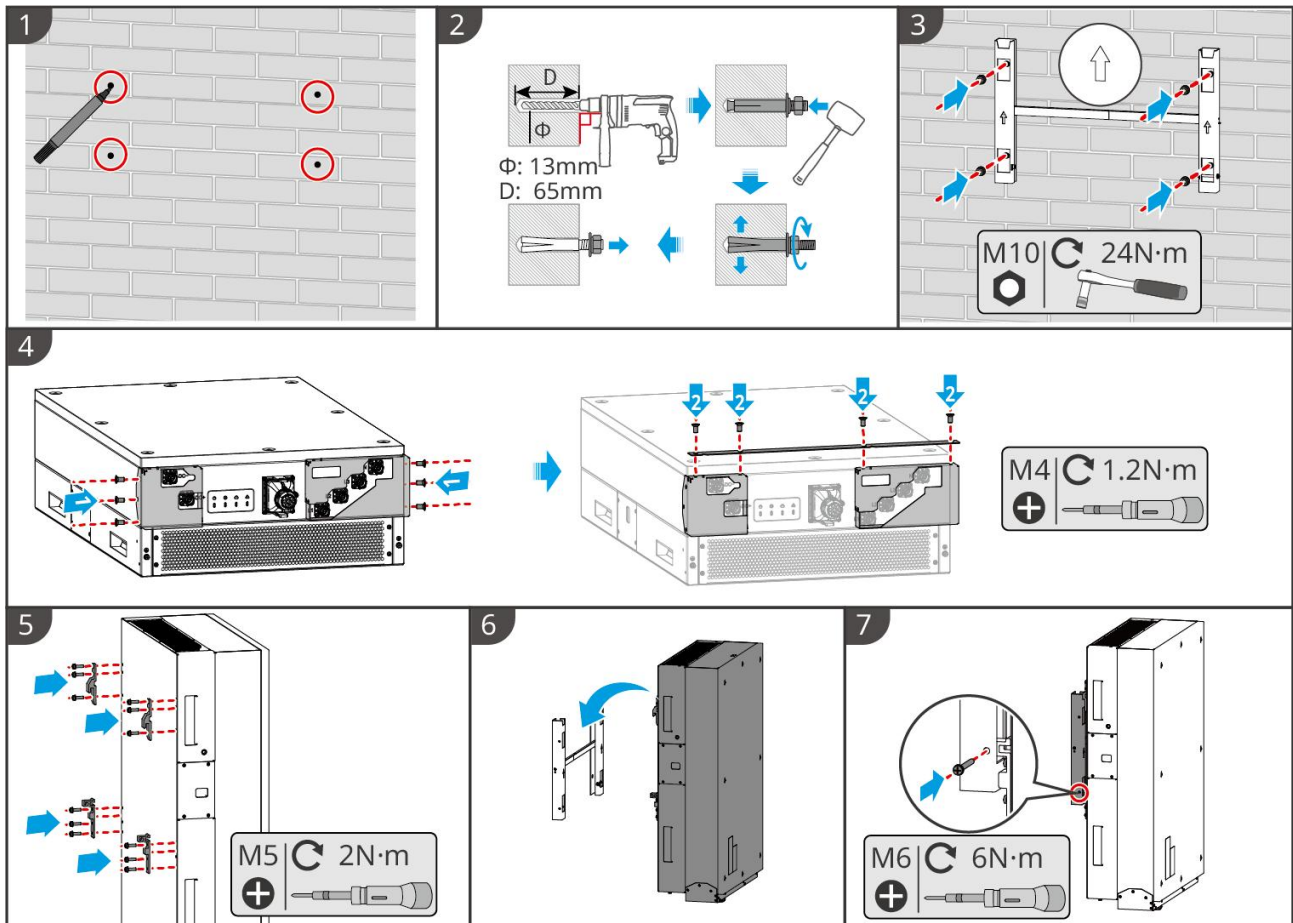

PCS10INT0016

### ■ Installed horizontally

Step 1: Assemble the mounting lugs.

Step 2: Install them onto the PCS.

Step 3: Install the protective cover.

Step 4: Place the PCS on the carrier.

Step 5: Secure the PCS with screws.

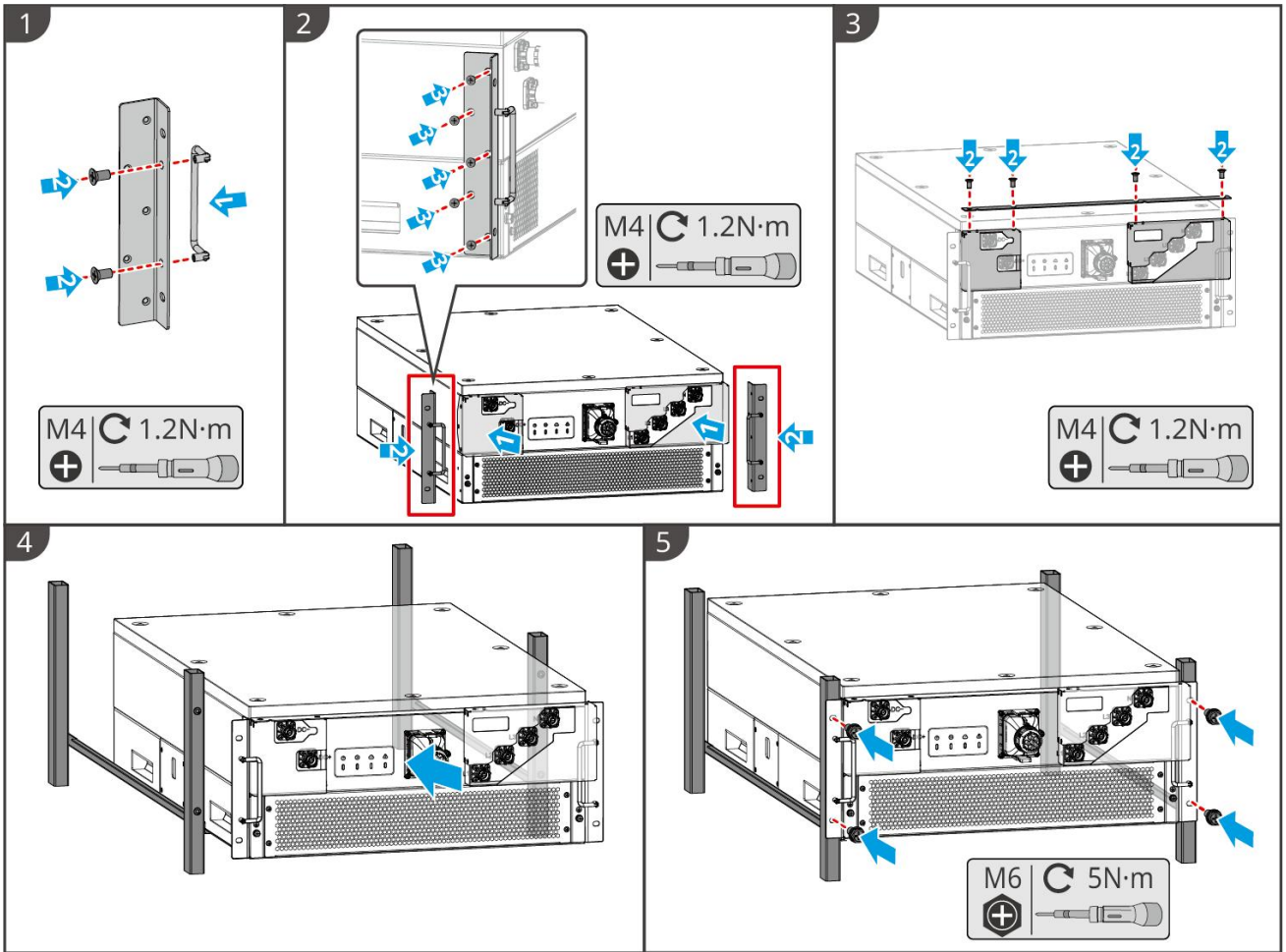

PCS10INT0017

● **Cabinet-mounted installation**

Step 1: Assemble the mounting lugs and install them onto the PCS.

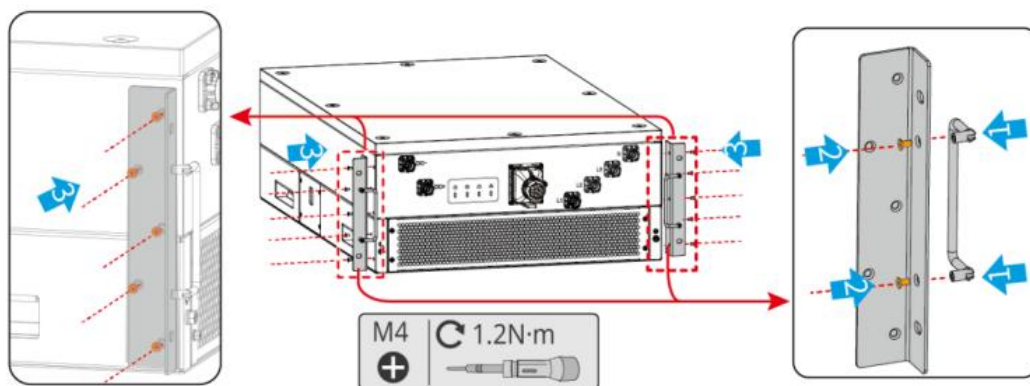

Step 2: Lift the PCS and carefully slide it into the cabinet.

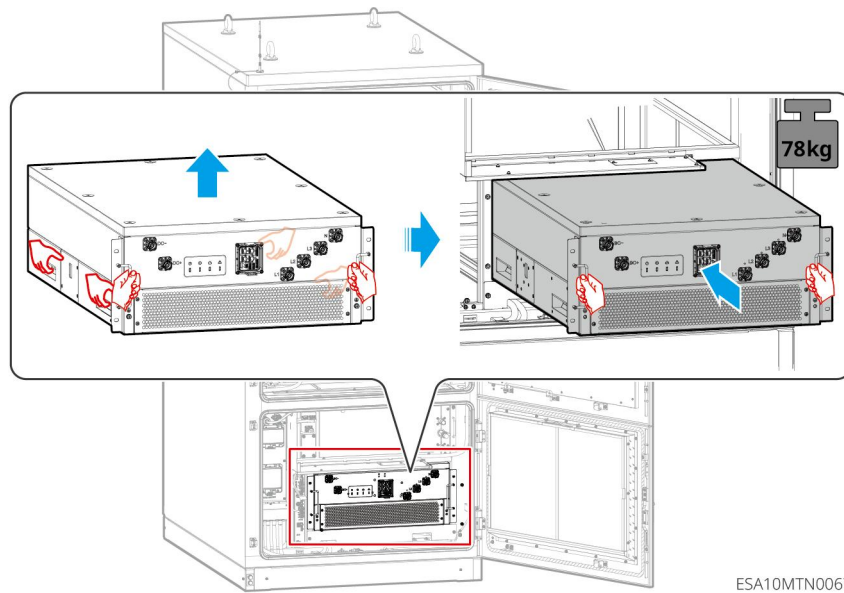

Step 3: Fasten the PCS to the cabinet.

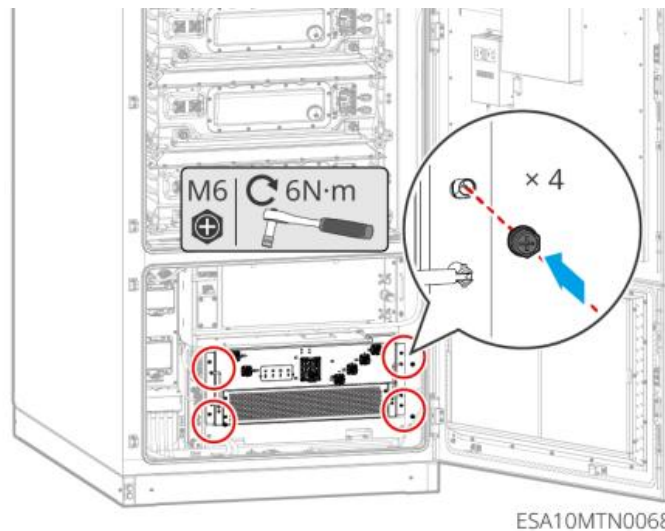

## 6 Electrical Connection

### DANGER

- Perform electrical connections in compliance with local laws and regulations. Including operations, cables, and component specifications.
- Disconnect the DC switch and the AC output switch of the inverter to power off the equipment before any electrical connections. Do not work with power on. Otherwise, an electric shock may occur.
- Cables of the same type should be bundled together and arranged separately from different types of cables. Intertwining or cross-arrangement is strictly prohibited.
- If the tension is too large, the cable may be poorly connected. Reserve a certain length of the

cable before connecting it to the PCS cable port.

- When crimping the wiring terminals, ensure that the conductor part of the cable is in full contact with the terminal. Do not crimp the cable insulation together with the terminal, as this may result in equipment malfunction or terminal block damage due to poor connection, overheating, and other related issues.
- Appropriate fire safety equipment, such as fire sand and carbon dioxide extinguishers, must be available on site.

### WARNING

- Damage to equipment caused by incorrect wiring is not covered under the warranty.
- Please strictly follow the internal wiring labels of the equipment for cable connections.
- Please ensure that the wire core is fully inserted into the terminal with no exposed parts to guarantee the safety and reliability of the connection.
- To avoid poor connections due to excessive tension on the cables, it is recommended to leave some slack in the cables before connecting them to the corresponding port.

### NOTICE

- When performing electrical connections, wear safety shoes, protective gloves, insulated gloves, etc., as required.
- Only qualified personnel are permitted to perform electrical connection operations.
- Permission from the local power authority is required for the on-grid operation of the PCS.
- Before connecting the power cable, it is essential to verify that the cable label is correctly identified and that the terminal of the cable has been properly insulated with protection.
- The selection, installation, and routing of cables must comply with local laws, regulations, and standards.
- During the installation of power cables, loops and twists are prohibited. If the power cable is short, it must be replaced with a new one. Splicing or soldering joints in the power cable is prohibited.
- All cables must be securely connected, well insulated, and of appropriate specifications.
- Cable trays and wire holes shall have no sharp edges. Protective measures must be applied at cable conduit entries or cable pass-through holes to prevent damage from sharp edges or burrs..
- Cables of the same type should be bundled together, with a straight and neat appearance and no outer sheath damage. Different types of cables should be routed separately, and mutual twisting or cross-routing is prohibited.

- Buried cables must be securely fixed using cable brackets and clamps. In areas where backfill soil is applied, ensure the cables are tightly attached to the ground to prevent deformation or damage caused by stress during backfilling.
- Cables used in high-temperature environments may experience insulation aging or damage. Keep cables away from heating components or heat sources.
- When making cables, make sure to stay away from the equipment to prevent cable debris from accidentally entering the device, which may cause arcing and result in personal injury.
- The cable colors shown in this document are for reference only. Actual cable specifications must comply with local regulations.
- All wiring procedures are applicable to both standalone installation and cabinet-mounted installation of PCS.

## NOTICE

- When using the PCS as a stand-alone unit, the cable protection cover must be removed with a tool before any cables can be disconnected from the PCS.
- Ensure the PCS is fully powered off before removing the protective cover and disconnecting the cables. Refer to [9.1 PCS Power Off](#) for power-off.
- When the PCS is installed and used inside a cabinet, it must be placed in a restricted access area (e.g., a cabinet with a door lock). To disconnect any cables from the PCS, the operator must first unlock and open the cabinet door using the key before proceeding with the cable disconnection.
- Please ensure that the cabinet is completely powered off before disconnecting the cable connections on the PCS. Refer to [9.1 PCS Power Off](#) for power-off.

## 6.1 Cable requirements

No.	cable	Cable type	Cable specification
1	External box protection grounding cable	Outdoor single core multi-strand copper cable	<ul style="list-style-type: none"> <li>• Conductor cross-sectional area: <math>S_{PE} \geq S/2</math></li> </ul>
2	DC & AC Cables (100kW PCS)	Outdoor single core multi-strand copper cable	<ul style="list-style-type: none"> <li>• Cable outer diameter: 13.1-13.9mm</li> <li>• Conductor cross-sectional area: <math>S=50\text{mm}^2</math></li> </ul>
3	DC & AC cables (125kW PCS)	Outdoor single core multi-strand copper cable	<ul style="list-style-type: none"> <li>• Cable outer diameter: 14.8-15.8mm</li> <li>• Conductor cross-sectional area:</li> </ul>

			S=70mm <sup>2</sup>
4	Communication cable (RJ45 connector)	Category 5E Shielded Ethernet Cable (standard network cable)	-
5	Communication Cable (others)	Outdoor shielded twisted Pair compliant with local standards	<ul style="list-style-type: none"> <li>• Cable outer diameter: 6.5-7mm</li> <li>• Conductor cross-sectional area: 0.75mm<sup>2</sup>-1.5mm<sup>2</sup></li> </ul>

**Note:**

1: S<sub>PE</sub> refers to PE cable conductor cross-sectional area, and S refers to AC cable conductor cross-sectional area. The values in this table are valid only if the external protective earth conductor is made of the same metal as the phase conductor. Otherwise, the cross-sectional area of the external protective earthing conductor shall be such that its conductivity is equivalent to that specified in this table. The PE conductor cross-sectional area shall be determined by calculation according to IEC 60345-5-54. (Other sizes of grounding cables that meet local standards and safety regulations can also be used for grounding connections. But GOODWE shall not be held liable for any damage caused.)

2: The total length of Communication cable cable must not exceed 1000m.

Model	Recommended RCD specifications
GW100K-PCS-N-G11 GW100K-PCS-N-G10	1000mA (Type A)
GW125K-PCS-N-G11 GW125K-PCS-N-G10	1250mA (Type A)

## 6.3 Connecting the PE cable

### WARNING

- Make sure that all the grounding points on the enclosures are equipotential connected when there are multiple PCSs.
- For electrical connection, the protective earth cable must be connected first; when removing the equipment, the protective earth wire must be disconnected last.
- The equipment grounding impedance shall comply with the requirements of local electrical standards.

### NOTICE

- The equipment shall be permanently connected to the protection ground. Before operating the equipment, check the electrical connections to ensure the equipment is reliably grounded.
- Do not operate the equipment without the proper connection of grounding conductors.
- Do not damage the grounding conductor.
- To improve the corrosion resistance of the terminal, it is recommended to apply silica gel or paint on the ground terminal after installing the PE cable.
- Please prepare PE cable by yourself.

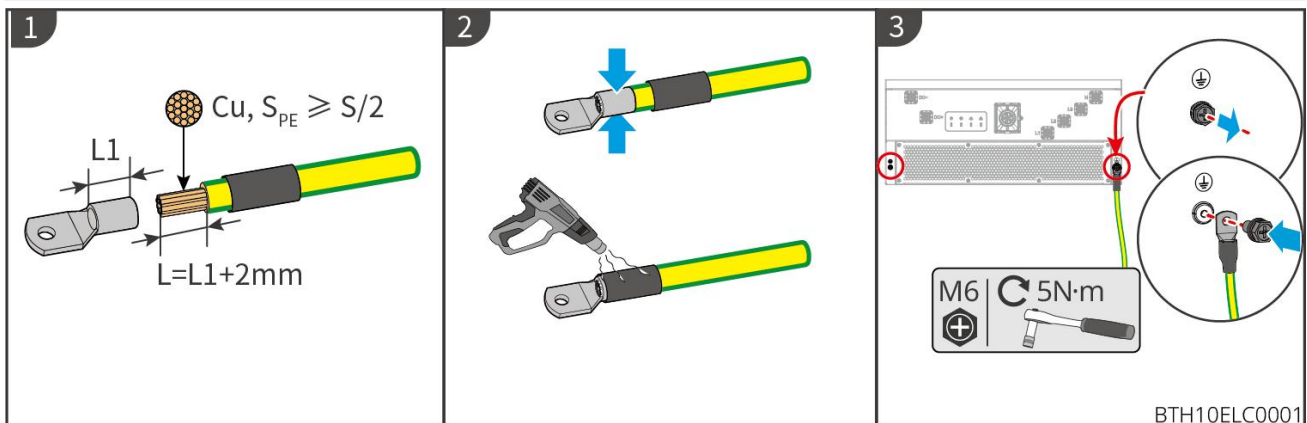

## 6.4 Connection Power Cable

### DC side

#### DANGER

- Before connecting the battery cable, ensure that the PCS and battery are POWER OFF, and that both the upstream and downstream switches of the equipment are disconnected.
- When the PCS is operating, it is prohibited to connect or disconnect the battery cable. Violation may result in electric shock.
- Do not connect the same battery to multiple PCS units, which may cause damage to the PCS.
- When connecting the battery cable, use insulated tools to prevent accidental electric shock or battery short circuit.

#### WARNING

- Please ensure that the cable connections are tight and the insulation is in good condition.
- Use a multimeter to measure the positive and negative poles of the DC cable, ensuring correct polarity without reverse connection, and confirm that the voltage is within the allowable range.
- The PCS supports connection to various model battery. When selecting battery connection cables, ensure the compatibility with the PCS DC terminal cable requirements.
- Please ensure that battery open-circuit voltage is within the permissible range of the PCS.
- All electrical wiring must be performed by qualified professional technicians.

#### NOTICE

- Please install the certified external DC isolator / breaker for isolating the battery source.
- A compliant isolation switch and current-limiting protection device must be installed between the PCS and battery. It is recommended to equip a breaker or equivalent device with a current > 200A. If the battery already has a switch and current-limiting device, the installation of this switch may be optional based on local laws and regulations.
- All electrical connection must comply with the power distribution standards of the installation country/region.
- Confirm the polarity of the cable and mark it accordingly.
- After the wiring is complete, it is prohibited to pull the cable horizontally, otherwise it may cause damage to the terminal.

## AC side

### WARNING

- It is prohibited to connect any load between the PCS and the AC Switch directly connected to the PCS.
- Ensure that the cable connections are securely fastened. otherwise, overheating of the terminal may occur during equipment operation, leading to damage.
- All electrical connection must comply with the power distribution standards of the installation country/region.

### NOTICE

- A disconnecting switch and current-limiting protection device must be installed between the PCS and utility grid. It is recommended to equip with a 400V<sub>AC</sub>/250A breaker or equivalent device.
- All electrical connection must comply with the power distribution standards of the installation country/region.

Breaker type	Recommended specifications
DC breaker	>200A <sup>*1</sup>
AC breaker	400V <sub>AC</sub> /250A

\*1: If there is a switch and current-limiting device on the battery, the installation of this switch can be chosen according to local laws and regulations.

### Wiring procedure

Step 1: Making the DC cable and crimping the quick-connect terminal.

Step 2: Connecting the cable to the PCS until a click sound is heard which indicates successful connection.

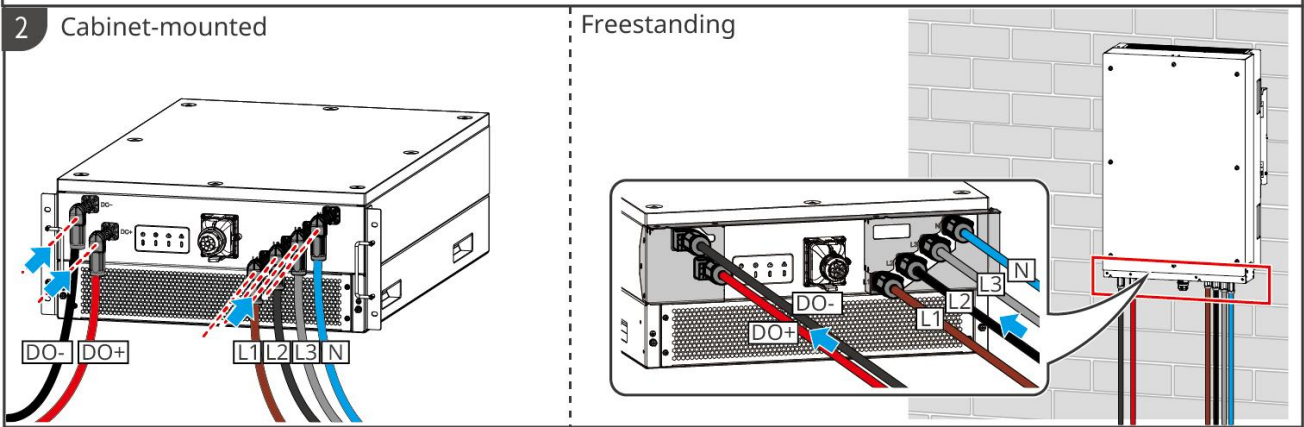
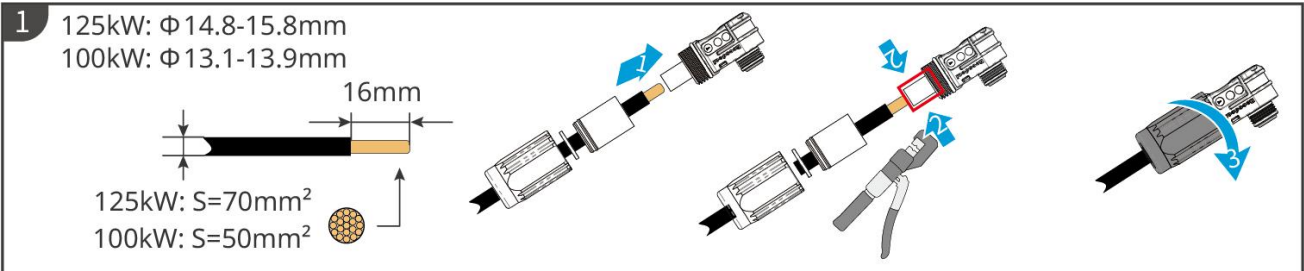

PCS10ELC0002

**Connecting to STS (GW500K-ST5-PCS-G10)**

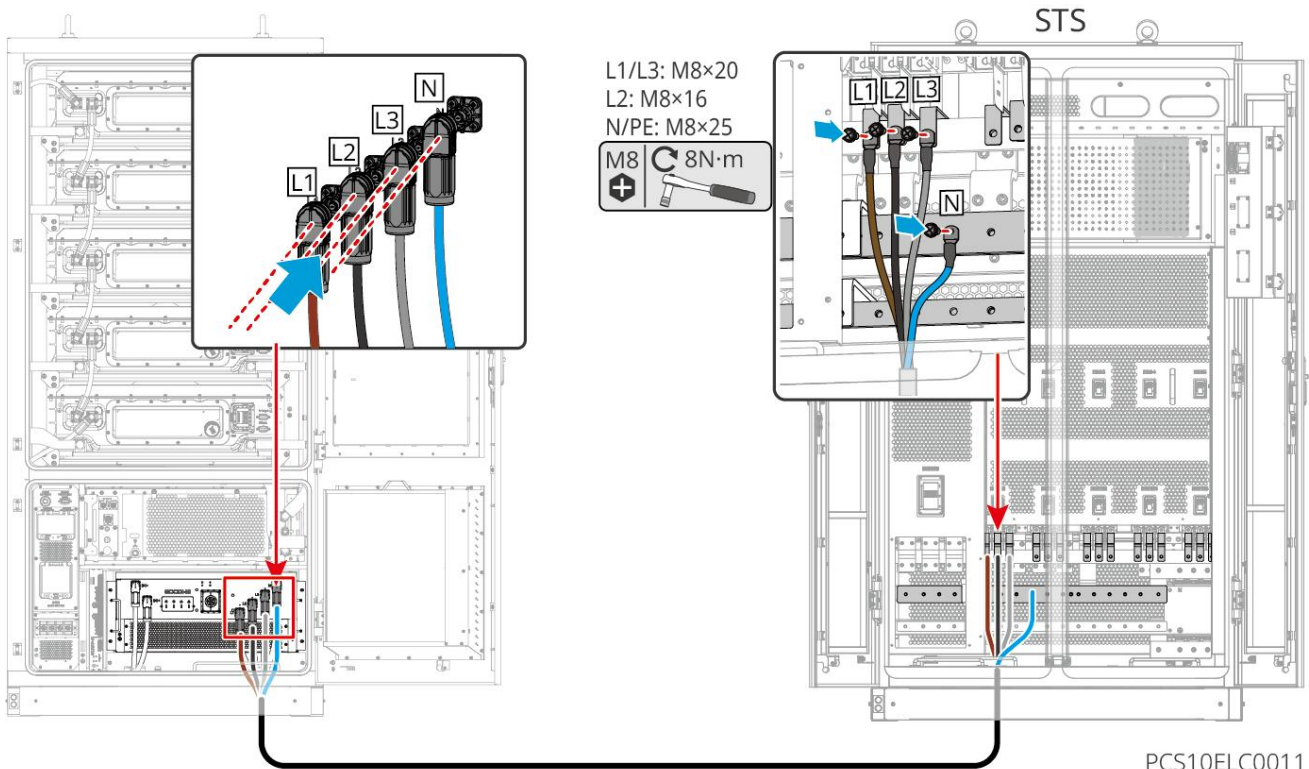

PCS10ELC0011

## 6.5 Connecting the Communication cable

### NOTICE

- When connecting communication cable, ensure that the wiring port definition exactly matches the equipment. The cable routing path should avoid interference sources, power cable, etc., to prevent affecting signal reception.
- To maintain the waterproof integrity of the PCS, unused plugs must be reinserted into the rubber stoppers.
- For RS485 or CAN communication, to ensure the communication quality between the PCS and connected devices (EMS, BMS, etc.), the connected devices themselves or the terminals must be equipped with a 120 ohm terminal resistor.
- The DIP switches are set to the ON position by default. When connecting multiple units in parallel, only the first and last PCS units require their DIP switches to be set to the ON position. All other PCS units should be manually set to the OFF position.

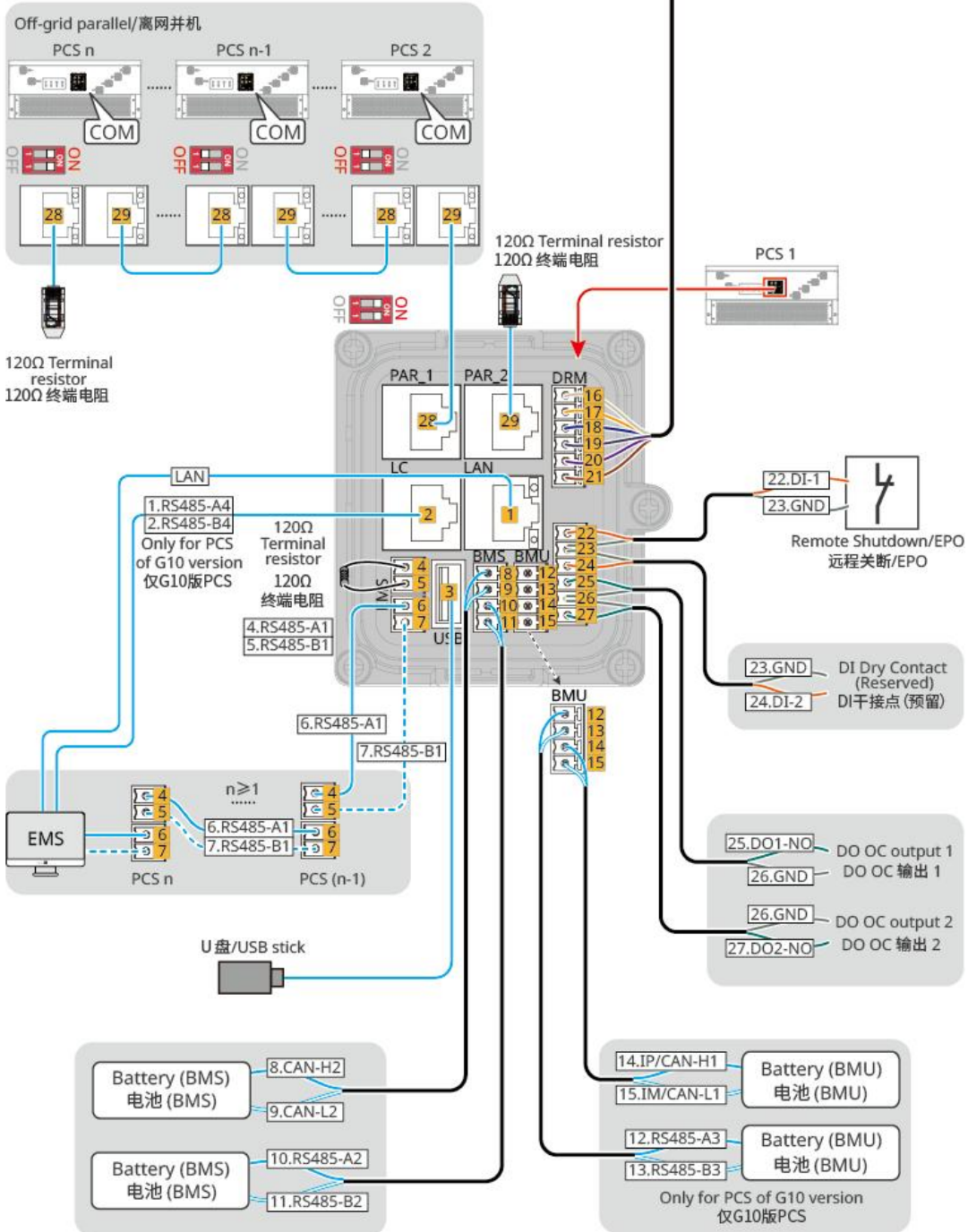
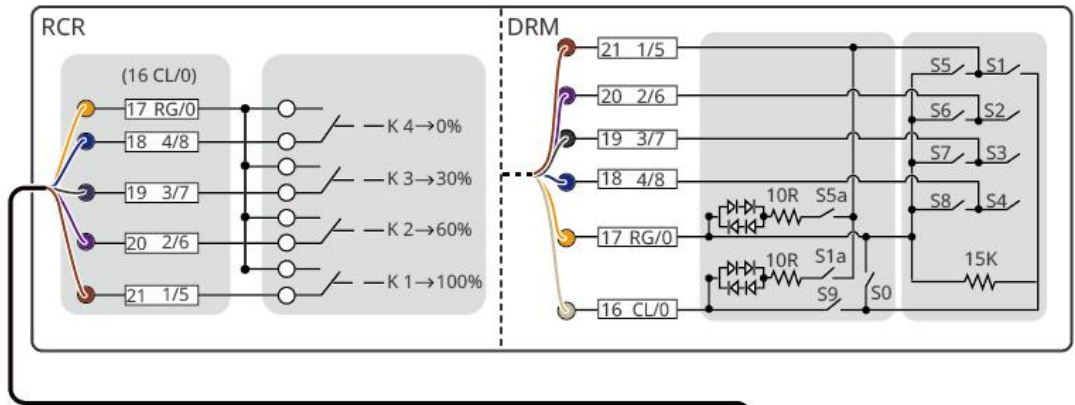

BTH10ELC0005

No.	Port Name /Connection Object	Port Definition	Functional Description
1	LAN	LAN	Connecting to EMS to enable Ethernet communication between PCS and EMS.
2	EMS	Pin1: RS485-A4  Pin2: RS485-B4	<ul style="list-style-type: none"> <li>Used to connect to the EMS, enabling communication between the PCS-integrated BCU and the EMS.</li> <li>Only applicable to G10 version PCS</li> </ul>
3	USB	USB	Connecting the USB flash drive for local upgrade and log export.
4	EMS	RS485-A1	<ul style="list-style-type: none"> <li>Connecting to EMS or terminal resistor to establish RS485 communication between PCS and EMS.</li> <li>Multiple PCS units can share one EMS function through daisy-chain wiring.</li> </ul>
5	EMS	RS485-B1	
6	EMS	RS485-A1	
7	EMS	RS485-B1	
8	BMS (Battery)	CAN-H2	Connecting the BMS to enable CAN communication between the PCS and BMS.
9	BMS (Battery)	CAN-L2	
10	BMS (Battery)	RS485-A2	Connecting BMS to achieve RS485 communication between PCS and BMS.
11	BMS (Battery)	RS485-B2	
12	BMU (Battery)	RS485-A3	<ul style="list-style-type: none"> <li>Connecting the BMU to enable RS485 communication between the PCS and BMU (optional).</li> <li>Only applicable to G10 version PCS</li> </ul>
13	BMU (Battery)	RS485-B3	
14	BMU (Battery)	IP/CAN-H1	<ul style="list-style-type: none"> <li>Connecting the BMU to enable communication between the PCS and BMU.</li> <li>Depending on the type of BCU, either daisy chain or CAN communication can be selected.</li> <li>Only applicable to G10 version PCS</li> </ul>
15	BMU (Battery)	IM/CAN-L1	

16	DRM/RCR	CL/0	Realizing Australian DRM (Demand Response Modes) functionality and provides DRED signal control for port.
17		RG/0	RCR Ripple Control Receiver: In Germany and some European regions, utility grid companies utilize the Ripple Control Receiver to convert utility grid dispatch signals into dry contact outputs. Power station receives the utility grid dispatch signals via dry contact communication.
18		4/8	
19		3/7	
20		2/6	
21		1/5	
22	-	DI-1	<ul style="list-style-type: none"> <li>● Dry contact input 1, EPO/Remote Shutdown</li> <li>● Emergency Power-off or remote shutdown, which can control the equipment to stop working in case of an accident</li> <li>● Configurable, default to normally closed</li> </ul>
23	-	GND	Common Ground Interface
24	-	DI-2	Dry contact input 2 (Reserved)
25	-	DO1-NO	Output Interface 1 (OC Output)
26	-	GND	Common ground Interface
27	-	DO2-NO	Output Interface 2 (OC output, supports PWM output, can be used for system fan speed control)
28	-	-	<ul style="list-style-type: none"> <li>● Achieve off-grid parallel operation of multiple PCS devices or connection to a terminal resistor</li> <li>● Parallel interface 1 and 2 have the same function.</li> </ul>
29	-	-	

## Wiring procedure

Step 1: Remove the communication connector from the PCS;

Step 2: Disassemble the communication connector.

Step 3: Crimp the communication cable or RJ45 connector;

Step 4: Connect the communication cable to the communication terminal and secure it, then pass the cable through the communication connector.

Step 5: Assemble the communication connector and connect it to the PCS.

Step 6: Tighten the communication connector.

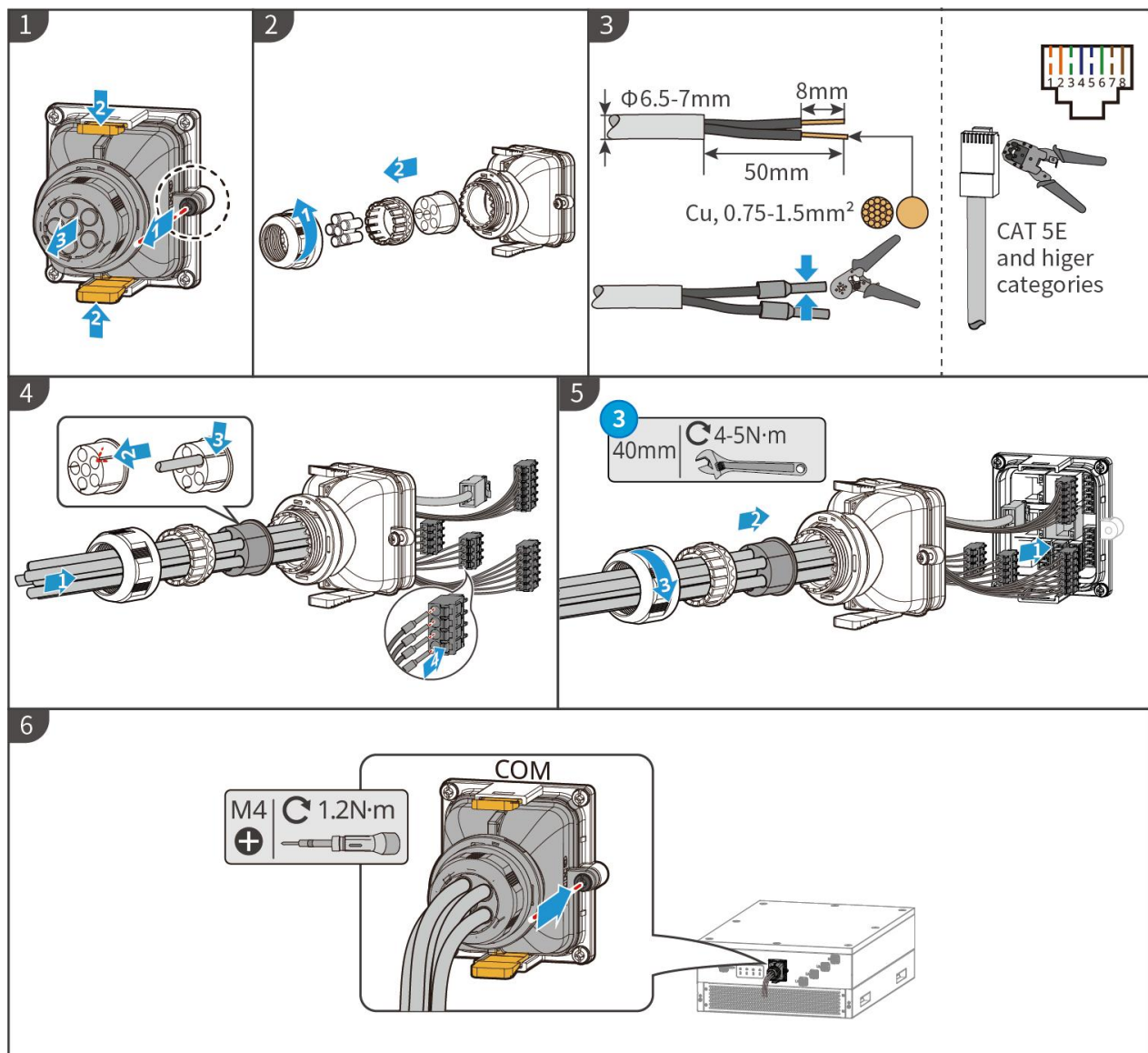

## 7 Equipment Commissioning

### 7.1 Check Items before Power ON

No.	Inspection items
1	The PCS is firmly installed in a clean place where is well-ventilated and easy to operate.
2	PE cable, DC cables, AC cables, Communication cable, etc., are correctly and securely connected.
3	Cable ties are routed properly and evenly, and no burrs.
4	Ensure that unused cable entry holes are covered with Installation waterproof caps.
5	Ensure that all used holes are properly sealed.
6	The voltage and frequency of the PCS on-grid connection point comply with the on-grid requirements.

### 7.2 Power On

#### NOTICE

- Before powering on the equipment, ensure that all items have been checked and confirmed to meet the requirements.
- The DC input voltage should be within the DC voltage range of the PCS, as specified in Chapter 10 Technical Parameter.
- Before closing the AC Switch between the PCS and the utility grid, use the multimeter AC voltage range to measure whether the AC voltage is within the allowable range (refer to the local utility grid standard).

Step 1: Close the AC Switch between the PCS AC side and utility grid.

Step 2: Close the DC switch between the DC side of the PCS and energy storage system.

Step 3: Issue the startup command via EMS and wait for the system to ramp up.

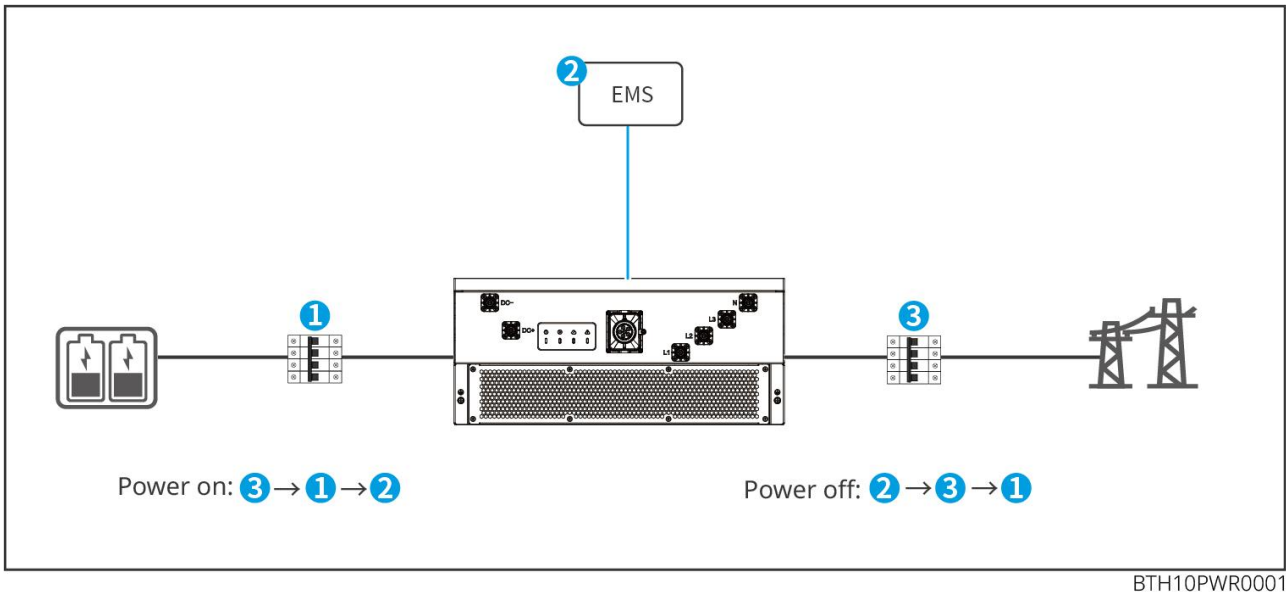

## 8 System Commissioning

### 8.1 Commissioning via a Host Computer

Please contact GoodWe after-sales service to obtain the commissioning tool and manual for the commissioning via a host computer.

### 8.2 Device Parameter Configuration via SolarGo

SolarGo app is a mobile application that communicates with the inverter via Bluetooth module or inverter. Commonly used functions are as follows:

- Check the operating data, software version, alarms, etc.
- Set the grid parameters, communication parameters, safety regulation regions and anti-backflow of the inverter.
- Equipment maintenance.

For more details, refer to the [SolarGo App User Manual](#). Get the user manual from the official site or by scanning the QR code below.



SolarGo App



SolarGo App User Manual

## 9 Maintenance

### 9.1 PCS Power Off

#### DANGER

- When performing operation and maintenance on the PCS, ensure the PCS is power off. Operating the equipment while energized may cause damage to the PCS or result in electric shock.
- After the PCS is powered off, the internal components require a certain amount of time to discharge. Please wait according to the label requirement until the device is completely de-energized.
- During equipment maintenance, hang a "Do Not Close the Switch" sign on the upstream and downstream switches or breaker, and post warning signs to prevent accidental connection. The power can be turned on again only after any fault is resolved.
- After disconnecting all PCS input power, wait for more than 5 minutes before opening the cover to inspect the PCS.

- **Standalone installation**

Step 1: Issue the shutdown command via EMS.

Step 2: Disconnect the AC Switch between the PCS AC side and the utility grid.

Step 3: Disconnect the DC switch between the DC side of the PCS and energy storage system.

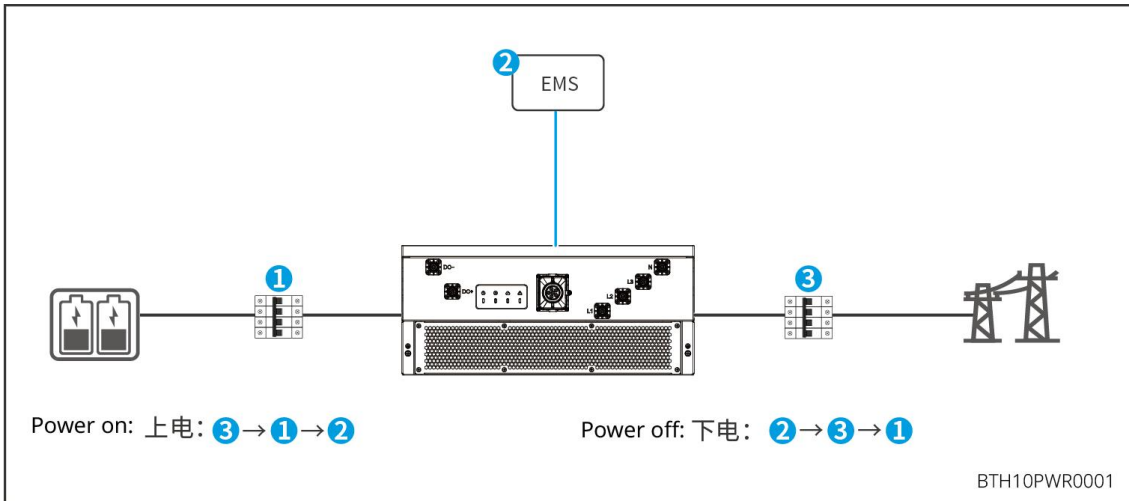

● **Cabinet-mounted**

Step 1: Send a shutdown command to the energy storage system via EMS.

Step 2: Observe that the RUN indicator light is solid white.

Step 3: Turn off Q1 (AC auxiliary switch).

Step 4: Turn off Q2 (DC auxiliary switch).

Step 5: Turn off QF1 (AC molded case circuit breaker).

Step 6: Turn off QF2 (DC circuit breaker).

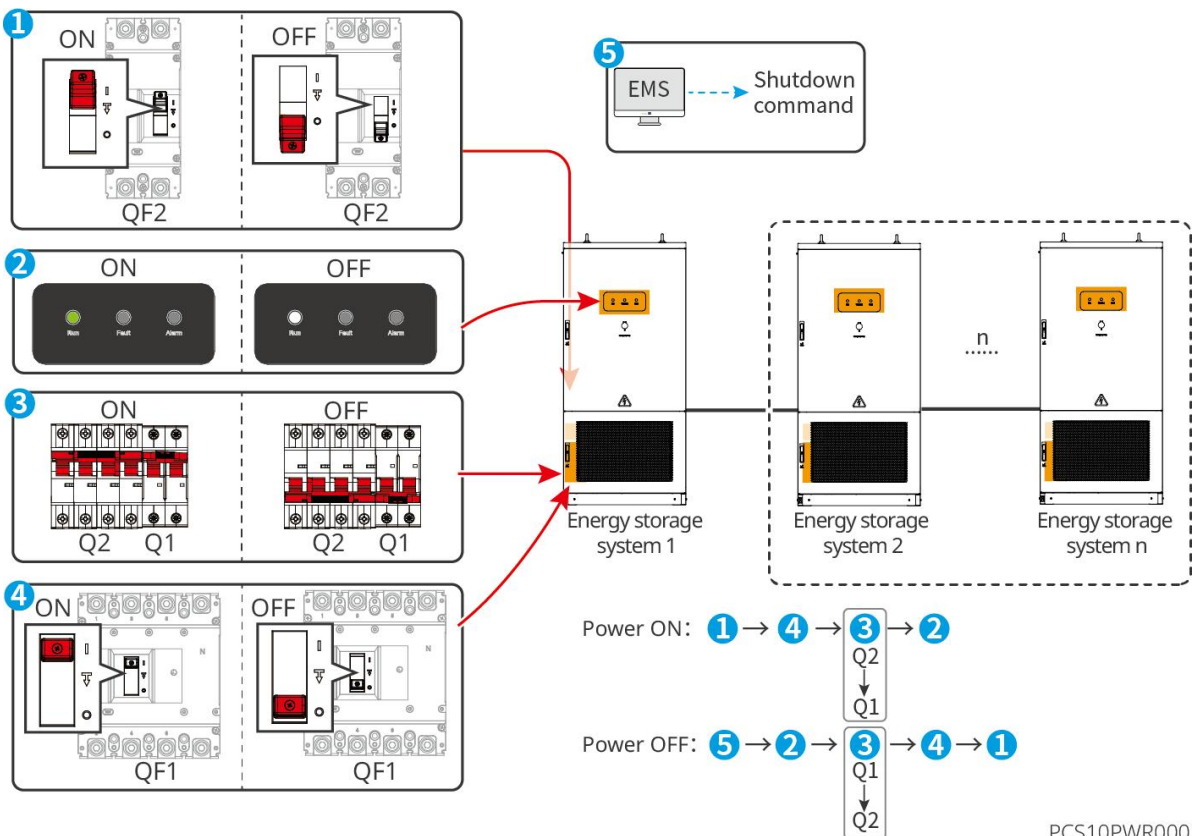

## 9.2 Removing the PCS

### WARNING

- Ensure that the PCS is POWER OFF.
- When operating the PCS, please wear personal protective equipment.

Step 1: Disconnect all electrical connections of the PCS, including: DC cables, AC cables, communication cable, PE cable, etc.

Step 2: Remove the PCS from the rail.

Step 3: Store the PCS properly. If the PCS is to be put into use again later, ensure that the storage conditions meet the requirements.

## 9.3 Disposing of the PCS

When the PCS can no longer be used and needs to be scrapped, it must be disposed of in accordance with the electrical waste disposal regulations of the country/region where the PCS is located. The PCS must not be treated as general household waste.

## 9.4 Troubleshooting

Please follow the troubleshooting steps below for fault. If the troubleshooting methods do not resolve the issue, please contact the after-sales service center.

When contacting the after-sales service center, please collect the following information to facilitate a quick resolution of the issue.

1. PCS information like software version, device installation time, fault occurrence time, fault occurrence frequency, etc.
2. Equipment installation environment, such as weather conditions, etc., system information, such as serial number and installation environment. Recommendations can include photos, videos, and other files to assist in problem analysis.
3. Utility grid condition.

No.	fault name	fault cause	Solution measures
1	utility grid lost fault	<ol style="list-style-type: none"><li>1. utility grid power outage.</li><li>2. AC line or AC Switch is</li></ol>	<ol style="list-style-type: none"><li>1. Verify whether other electrical equipment under the same</li></ol>

		disconnected.	<p>on-grid point is functioning normally and whether the utility power is operating correctly.</p> <ol style="list-style-type: none"> <li>2. Confirm whether the upper-level AC Switch of the product is closed.</li> <li>3. Verify that the AC line phase is correctly connected, and the PE wiring sequence is correct and secure.</li> </ol>
2	Overvoltage and Undervoltage Protection	utility grid voltage exceeds the allowable range, or the duration of overvoltage surpasses the set value for high voltage ride-through.	<ol style="list-style-type: none"> <li>1. If it occurs occasionally, it may be due to a temporary abnormality in utility grid. The PCS will resume normal operation upon detecting that utility grid has returned to normal, without requiring manual intervention.</li> </ol>
		utility grid voltage is below the permissible range, or the duration of low voltage exceeds the low voltage ride-through setting value.	<ol style="list-style-type: none"> <li>2. If it occurs frequently, check whether utility grid and voltage are within the allowable range.</li> </ol> <ul style="list-style-type: none"> <li>● If the utility grid voltage exceeds the allowable range, please contact the</li> </ul>

			<p>local power Power operator.</p> <ul style="list-style-type: none"> <li>● If utility grid voltage is within the allowable range, it is necessary to obtain the consent of the</li> </ul> <p>After obtaining approval from the local power operator, modify the PCS overvoltage trip point or disable the overvoltage protection function.</p> <p>3. If the issue persists for an extended period, please check whether the breaker on the AC side and the output cables are properly connected.</p>
3	Overvoltage fast Fast Protection	Abnormal utility grid voltage or excessively high voltage triggers fault.	<p>1. If it occurs occasionally, it may be due to a temporary abnormality in utility grid. The PCS will resume normal operation after detecting that utility grid is normal, without requiring manual intervention.</p> <p>2. Check if the utility grid voltage has been operating at a high voltage for an</p>

			<p>extended period. If this occurs frequently, verify whether the utility grid voltage is within the allowable range.</p> <ul style="list-style-type: none"> <li>● If the utility grid voltage exceeds the allowable range, please contact the local power Force operator.</li> <li>● If the utility grid voltage is within the allowable range, local approval is required.</li> </ul> <p>After obtaining approval from the power operator, modify the utility grid voltage.</p>
4	10min overvoltage Protection	Within 10 minutes, the sliding average of utility grid voltage exceeds the safety regulation limits.	<ol style="list-style-type: none"> <li>1. If it occurs occasionally, it may be due to a temporary anomaly in utility grid. The PCS will resume normal operation after detecting that utility grid is back to normal, without requiring manual intervention.</li> <li>2. Check if the utility grid voltage is operating at a high voltage for an extended period. If</li> </ol>

			<p>this occurs frequently, verify whether the utility grid voltage is within the allowable range.</p> <ul style="list-style-type: none"> <li>● If the utility grid voltage exceeds the allowable range, please contact the local power Power operator.</li> <li>● If the utility grid voltage is within the allowable range, local approval is required.</li> </ul> <p>After approval by the power operator, modify the utility grid voltage.</p>
5	over/under frequency	utility grid anomaly, utility grid actual Frequency exceeds local utility grid standard requirements.	<ol style="list-style-type: none"> <li>1. If it occurs occasionally, it may be due to a temporary anomaly in utility grid. The PCS will resume normal operation after detecting that utility grid is back to normal, without requiring manual intervention.</li> <li>2. If it occurs frequently, check whether the utility grid and Frequency are within the allowable range.</li> </ol> <ul style="list-style-type: none"> <li>● If the utility grid</li> </ul>

			<p>frequency exceeds the allowable range, please contact the local authorities.</p> <p>Power operator.</p> <ul style="list-style-type: none"> <li>● If utility grid frequency is within the allowable range, it is necessary to obtain consent from the relevant</li> </ul> <p>After obtaining approval from the local power operator, modify the PCS over-frequency protection settings.</p> <p>Enable or disable the over-frequency Protection function.</p>
		<p>utility grid anomaly, utility grid actual Frequency is below the local utility grid standard requirement.</p>	<ol style="list-style-type: none"> <li>1. If it occurs occasionally, it may be due to a temporary abnormality in utility grid. The PCS will resume normal operation upon detecting that utility grid has returned to normal, without requiring manual intervention.</li> <li>2. If it occurs frequently, check whether utility grid Frequency is within the allowable range.</li> </ol> <ul style="list-style-type: none"> <li>● If the utility grid</li> </ul>

			<p>frequency exceeds the allowable range, please contact the local</p> <p>Power operator.</p> <ul style="list-style-type: none"> <li>● If the utility grid frequency is within the allowable range, it is necessary to obtain the consent of the</li> </ul> <p>After obtaining approval from the local power operator, modify the PCS under-frequency protection settings. Enable or disable the underfrequency Protection function.</p>
6	Leakage current	During product operation, the input-to-ground insulation resistance becomes low.	<ol style="list-style-type: none"> <li>1. Check whether the operating environment of the product meets the requirements. For example, during rainy weather, errors may occur due to high Humidity.</li> <li>2. Ensure the modules are properly grounded; the AC output side is well grounded.</li> <li>3. Disconnect the AC output side switch</li> </ol>

			and DC input side switch, then close the AC output side switch and DC input side switch after 5 minutes. If the fault persists, please contact your dealer or after-sales service center.
7	insulation resistance Protection	Machine detection shows insulation resistance to ground is below the normal value.	Please check the input side for any ground faults.
8	Internal CAN communication error	-	Disconnect the AC output side switch and the DC input side switch. After 5 minutes, close the AC input side switch and the DC input side switch. If the fault persists, please contact your dealer or after-sales service center.
9	CT self-test fault	There is an anomaly in the sampling of the AC sensor.	Disconnect the AC output side switch and DC input side switch, wait for 5 minutes, then close the AC input side switch and DC input side switch. If the fault
10	GFCI module self-test error	<ol style="list-style-type: none"> <li>1. During the product self-test, the input-to-ground insulation resistance becomes low.</li> <li>2. Leakage current sensor sampling anomaly detected.</li> </ol>	

11	Relay self-test abnormality	<ol style="list-style-type: none"> <li>1. Relay anomaly (relay short circuit).</li> <li>2. Control circuit abnormality.</li> <li>3. Abnormal AC measurement wiring (possible loose connection or short circuit).</li> </ol>	persists, please contact your dealer or after-sales service center.
12	DC relay error	<ol style="list-style-type: none"> <li>1. Internal relay abnormality in the product.</li> <li>2. Control circuit abnormality.</li> </ol>	Disconnect the AC output side switch and DC input side switch, then reconnect the AC output side switch and DC input side switch after 5 minutes. If the fault persists, please contact your dealer or after-sales service center.
13	flash	Memory chip anomaly.	<ol style="list-style-type: none"> <li>1. Check whether the ventilation of the PCS is adequate and whether the ambient temperature exceeds the maximum allowable range.</li> <li>2. If there is no ventilation or the ambient temperature is too high, improve its ventilation and heat dissipation conditions.</li> <li>3. If ventilation and</li> </ol>
14	Module temperature over-temperature	<ol style="list-style-type: none"> <li>1. The product Installation Location is not ventilated.</li> <li>2. Ambient temperature is too high.</li> <li>3. Internal fan operation abnormal.</li> </ol>	

			ambient temperature are normal, please contact your dealer or after-sales service center.
15	1.5V reference anomaly	Reference circuit abnormality.	Disconnect the AC output side switch and DC input side switch, then close the AC output side switch and DC input side switch after 5 minutes. If the fault persists, please contact your dealer or after-sales service center.
16	3V reference anomaly	Reference circuit abnormality.	
17	Model identification error	<ol style="list-style-type: none"> <li>1. Environmental factors cause temporary abnormalities.</li> <li>2. Internal components of the product are damaged.</li> </ol>	Disconnect the AC output side switch and DC input side switch after 5 minutes. If the fault persists, please contact your dealer or after-sales service center.
18	BUS overvoltage	<ol style="list-style-type: none"> <li>1. Battery voltage is too high.</li> <li>2. Product BUS voltage sampling anomaly.</li> </ol>	<ol style="list-style-type: none"> <li>1. Check the Battery status.</li> <li>2. Disconnect the AC output side switch and the DC input side switch, then close the AC output side switch and the DC input side switch after 5 minutes. If the fault persists, please contact your dealer or after-sales service center.</li> </ol>
19	BUSvoltage Low	<ol style="list-style-type: none"> <li>1. Battery voltage is too low.</li> <li>2. Product BUS voltage sampling anomaly.</li> </ol>	
20	BUS soft start failure	<ol style="list-style-type: none"> <li>1. DC contactor abnormal.</li> <li>2. Product BUS voltage sampling anomaly.</li> </ol>	
21	BUS imbalance	Product BUSvoltage sampling anomaly.	
22	GPLD inverter continuous overcurrent	<ol style="list-style-type: none"> <li>1. Inverter sampling anomaly.</li> <li>2. Hardware damage.</li> </ol>	

23	Software inverter software overcurrent	<ol style="list-style-type: none"> <li>1. Inverter sampling anomaly.</li> <li>2. Hardware damage.</li> </ol>	then close the AC output side switch and DC input side switch after 5 minutes. If the fault persists, please contact your dealer or after-sales service center.
24	CPLD (Complex Programmable Logic Device)	<ol style="list-style-type: none"> <li>1. Environmental factors cause temporary abnormalities.</li> <li>2. The internal chip of the product is damaged.</li> </ol>	Disconnect the AC output side switch and DC input side switch, then close the AC output side switch and DC input side switch after 5 minutes. If the fault persists, please contact your dealer or after-sales service center.
25	Fan fault (Internal External)	<ol style="list-style-type: none"> <li>1. Abnormal fan power supply.</li> <li>2. Mechanical fault (locked rotor).</li> <li>3. Fan aging and damage.</li> </ol>	Please check if there is any foreign object blocking the fan. If the fault persists, please contact your dealer or after-sales service center.

## 9.5 Routine Maintenance

<b>DANGER</b>
<p>When performing operation and maintenance on the PCS, ensure the PCS is power off handled. Operating the equipment while energized may cause damage to the PCS or result in electric shock DANGER.</p>

## NOTICE

- If the cable is damaged, it must be replaced by a professional to avoid risks.
- Do not use water, alcohol, oil, or other solvents to clean the internal or external electrical components of the equipment.

<b>Maintenan ce content</b>	<b>Maintenance method</b>	<b>Maintenance cycle</b>
Dust removal and maintenance of radiator air inlet and outlet	Check the heat sink and air inlet/outlet for any foreign objects or dust. If necessary, disassemble the fan for inspection and cleaning.	1 times/half year
Fan	Check if the fan has any abnormal noise; Check the fan blades for cracks; Check if the fan has abnormal blockage or stalling; Check if the fan has derating.	1 times/half year
Cable connection	Check whether the AC DC cable is reliably connected and whether there is any damage; Check whether the cable connector is tightened; Check whether the grounding wire is securely connected.	1 times/half year

Follow below steps to maintain the fans:

The PCS is equipped with an external fan module. For thorough cleaning, please remove the fan from the unit before cleaning.

1. Power off the PCS power.
2. Wait until the residual voltage is released and the fan stops running as per the label requirements.
3. Clean the fan.
  - Use screwdriver to remove screw, then extract the fan;
  - Please pull out the entire external fan module as a whole; do not pull out individual fans.
4. Please clean with a soft bristle brush, cloth, or vacuum cleaner.
5. After cleaning, reassemble the fan and tighten the screw.

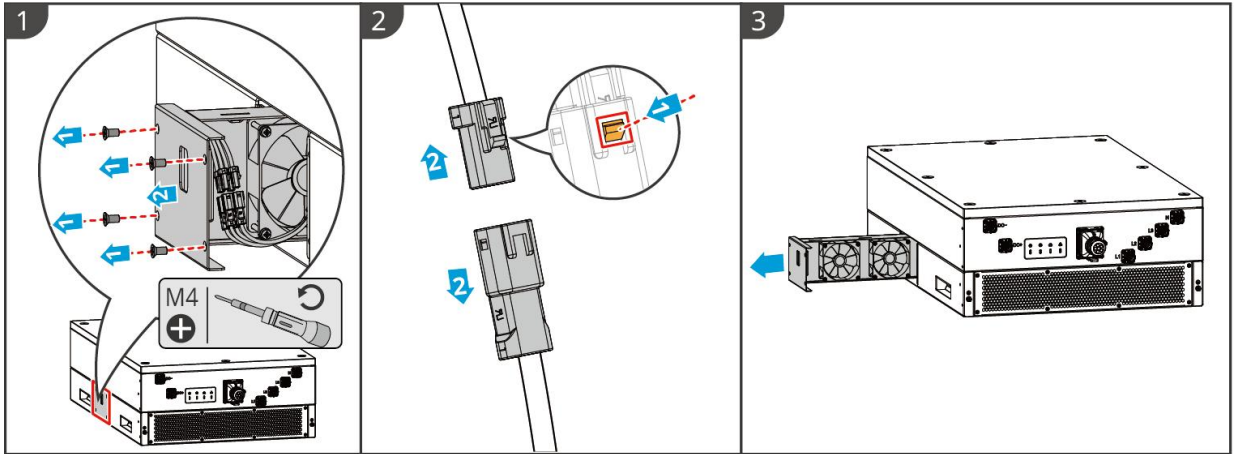

BTH10MTN0002

# 10 Technical Parameter

## PCS

Technical Data	GW100K-PCS-N-G10	GW125K-PCS-N-G10	GW100K-PCS-N-G11	GW125K-PCS-N-G11
<b>Battery Input Data</b>				
Battery Type	Li-Ion	Li-Ion	Li-Ion	Li-Ion
Nominal Operating Voltage	832	832	832	832
Nominal Operating Voltage Range (V) *1	680~936	680~936	680~936	680~936
Start-up Voltage (V)	680	680	680	680
Operating Voltage Range (V)	670~1000	670~1000	670~1000	670~1000
Max. DC Voltage (V)	1000	1000	1000	1000
Number of Battery Input	1	1	1	1
Max. Continuous Charging Current (A)	158.8	198.5	158.8	198.5
Max. Continuous Discharging Current (A)	158.8	198.5	158.8	198.5
Max. Short Circuit Current (A)	225	225	225	225
Max. Continuous Charging Power	110.0	137.5	110.0	137.5

(kW)				
Max. Continuous Discharging Power (kW)	110.0	137.5	110.0	137.5
<b>AC Output Data (On-grid)</b>				
Nominal Output Power (kW)	100	125	100	125
Max. Output Power (kW)	110@400V AC 104.5@380V AC	137.5@400V AC 130.6@380V AC	110@400V AC 104.5@380V AC	137.5@400V AC 130.6@380V AC
Nominal Apparent Power (kVA)	100	125	100	125
Nominal Output Voltage (V)	400/380, 3L/N/PE	400/380, 3L/N/PE	400/380, 3L/N/PE	400/380, 3L/N/PE
Output Voltage Range (V)	340~440/ 323~418	340~440/ 323~418	340~440/ 323~418	340~440/ 323~418
Nominal AC Grid Frequency (Hz)	50/60	50/60	50/60	50/60
AC Grid Frequency Range (Hz)	47.5~52.5 /57.5~62.5	47.5~52.5 /57.5~62.5	47.5~52.5 /57.5~62.5	47.5~52.5 /57.5~62.5
Max. Output Apparent Power to Grid (kVA)	110@400V AC 104.5@380V AC	137.5@400V AC 130.6@380V AC	110@400V AC 104.5@380V AC	137.5@400V AC 130.6@380V AC
Max. Input Apparent Power from Grid (kVA)	110@400V AC 104.5@380V AC	137.5@400V AC 130.6@380V AC	110@400V AC 104.5@380V AC	137.5@400V AC 130.6@380V AC
Max. AC Current Output to utility Grid (A)	158.8	198.5	158.8	198.5
Max. AC Current from utility Grid (A)	158.8	198.5	158.8	198.5
Nominal AC Current from	144.3@400V	180.4@400V	144.3@400V	180.4@400V

Utility Grid (A)	151.9@380V	189.9@380V	151.9@380V	189.9@380V
Nominal Output Current (A)	144.3@400V 151.9@380V	180.4@400V 189.9@380V	144.3@400V 151.9@380V	180.4@400V 189.9@380V
Inrush Current (Peak and Duration) (A)	360	360	360	360
Max. Short Circuit Current (A)	360	360	360	360
Power Factor	~1(0.8lag to 0.8lead)			
Max. Total Harmonic Distortion	<3%	<3%	<3%	<3%
Maximum Output Overcurrent Protection (A)	360	360	360	360
<b>AC Output Data (Off-grid)</b>				
Nominal Apparent Power (kVA)	100	125	100	125
Max. Output Apparent Power (kVA)	110@400V AC 104.5@380V AC	137.5@400V AC 130.6@380V AC	110@400V AC 104.5@380V AC	137.5@400V AC 130.6@380V AC
Nominal Output Current (A)	144.3@400V 151.9@380V	180.4@400V 189.9@380V	144.3@400V 151.9@380V	180.4@400V 189.9@380V
Max. Output Current (A)	158.8	198.5	158.8	198.5
Max. Output Fault Current (Peak and Duration) (A)	360	360	360	360
Inrush Current (Peak and Duration) (A)	360	360	360	360
Maximum Output Overcurrent	360	360	360	360

Protection (A)				
Nominal Output Voltage (V)	400/380, 3L/N/PE	400/380, 3L/N/PE	400/380, 3L/N/PE	400/380, 3L/N/PE
Nominal Output Frequency (Hz)	50/60	50/60	50/60	50/60
Output THDv (@Linear Load)	<3%	<3%	<3%	<3%
Power Factor	~1(0.8lag to 0.8lead)			
<b>Efficiency</b>				
Max. Efficiency	98.6%	98.6%	98.6%	98.6%
European Efficiency	98.6%	98.6%	98.6%	98.6%
<b>Protection</b>				
Residual Current Monitoring	Integrated	Integrated	Integrated	Integrated
Battery Reverse Polarity Protection	Integrated	Integrated	Integrated	Integrated
Anti-islanding Protection	Integrated	Integrated	Integrated	Integrated
AC Overcurrent Protection	Integrated	Integrated	Integrated	Integrated
AC Short Circuit Protection	Integrated	Integrated	Integrated	Integrated
AC Overvoltage Protection	Integrated	Integrated	Integrated	Integrated
DC Switch	N/A	N/A	N/A	N/A
AC Switch	N/A	N/A	N/A	N/A
DC Surge Protection	Type II	Type II	Type II	Type II
AC Surge Protection	Type II	Type II	Type II	Type II
<b>General Data</b>				

Operating Temperature Range (°C) *2	-25~+60	-25~+60	-25~+60	-25~+60
Derating temperature (°C) *3	50	50	50	50
Relative Humidity	0 ~ 100%	0 ~ 100%	0 ~ 100%	0 ~ 100%
Max. Operating Altitude (m)	4000	4000	4000	4000
Cooling Method	Smart Fan Cooling	Smart Fan Cooling	Smart Fan Cooling	Smart Fan Cooling
User Interface	LED	LED	LED	LED
Communication	RS485, CAN, Ethernet	RS485, CAN, Ethernet	RS485, CAN, Ethernet	RS485, CAN, Ethernet
Communication Protocols	Modbus RTU, Modbus TCP	Modbus RTU, Modbus TCP	Modbus RTU, Modbus TCP	Modbus RTU, Modbus TCP
Weight (kg)	80	80	80	80
Dimension (W×H×D mm)	600*266*900	600*266*900	600*266*900	600*266*900
Noise Emission (dB)	<68	<68	<68	<68
Topology	Non-isolated	Non-isolated	Non-isolated	Non-isolated
Ingress Protection Rating	IP66	IP66	IP66	IP66
Environmental Category	4K4H	4K4H	4K4H	4K4H
Pollution Degree	III	III	III	III
Overtoltage Category	DC II / AC III	DC II / AC III	DC II / AC III	DC II / AC III
Protective Class	I	I	I	I
The Decisive Voltage Class (DVC)	Battery: C AC: C Com: A	Battery: C AC: C Com: A	Battery: C AC: C Com: A	Battery: C AC: C Com: A
Active	AFDPF+AQDPF	AFDPF+AQDPF	AFDPF+AQDPF	AFDPF+AQDPF

Anti-islanding Method				
Type of Electrical Supply System	TN-S, TN-C, TN-C-S, TT	TN-S, TN-C, TN-C-S, TT	TN-S, TN-C, TN-C-S, TT	TN-S, TN-C, TN-C-S, TT
Country of Manufacture	China	China	China	China
Integrated PDU	Integrated	Integrated	/	/

Note:

\*1 For the three-phase 400V AC output. The full-load voltage range of the DC is from 705V to 936V.

\*2 the auxiliary power supply can start up at -30 °C.

\*3 1.1 times overload derating temperature: 40°C.

## STS (GW500K-ST5-PCS-G10)

Technical Data	GW500K-ST5-PCS-G10
<b>Grid</b>	
Nominal Voltage (V)	220/380, 230/400, 3L/N/PE
Voltage Range (V)	340~440
Nominal Frequency (Hz)	50/60
Frequency Range (Hz)	47.5~52.5 /57.5~62.5
Rated. Current (A)	957.2
Max. Current (A)	1000@10s
Rated Power (kW)	500
Max. Apparent Power (kVA)	630
Rated Conditional Short-time Current (kA)	20
<b>Back-up</b>	
Nominal Voltage (V)	220/380, 230/400, 3L/N/PE

<b>Technical Data</b>	<b>GW500K-ST5-PCS-G10</b>
Voltage Range (V)	340~440
Nominal Frequency (Hz)	50/60
Frequency Range (Hz)	47.5~52.5 /57.5~62.5
Rated. Current (A)	835.6
Max. Current (A)	1000@10s
Rated Power (kW)	500
Max. Apparent Power (kVA)	550
Rated Conditional Short-time Current (kA)	20
<b>ESS</b>	
Nominal Voltage (V)	220/380, 230/400, 3L/N/PE
Voltage Range (V)	340~440
Nominal Frequency (Hz)	50/60
Frequency Range (Hz)	47.5~52.5 /57.5~62.5
Rated. Current (A)	835.6
Max. Current (A)	1000@10s
Rated Power (kW)	500
Max. Apparent Power (kVA)	550
Rated Conditional Short-time Current (kA)	20
<b>Smart-port</b>	
Nominal Voltage (V)	220/380, 230/400, 3L/N/PE
Voltage Range (V)	340~440
Nominal Frequency (Hz)	50/60
Frequency Range (Hz)	47.5~52.5 /57.5~62.5
Rated. Current (A)	835.6

<b>Technical Data</b>	<b>GW500K-ST5-PCS-G10</b>
Max. Current (A)	1000@10s
Rated Power (kW)	500
Max. Apparent Power (kVA)	550
Rated Conditional Short-time Current (kA)	20
<b>Inverter</b>	
Nominal Voltage (V)	220/380, 230/400, 3L/N/PE
Voltage Range (V)	340~440
Nominal Frequency (Hz)	50/60
Frequency Range (Hz)	47.5~52.5 / 57.5~62.5
Rated. Current (A)	1519.4
Max. Current (A)	1800@10s
Rated Power (kW)	1000 (Centralized Access 500 + Independent Access 500)
Max. Apparent Power (kVA)	1000 (Centralized Access 500 + Independent Access 500)
Rated Conditional Short-time Current (kA)	20
<b>General Data</b>	
On/Off Grid Transfer Time (ms)	<20
Operating Temperature Range (°C)	-25~+55
Storage Temperature (°C)	-40~+70
Relative Humidity	0~100%
Pollution Degree	III
Max. Operating Altitude (m)	4000
Cooling Method	Smart Fan Cooling

<b>Technical Data</b>	<b>GW500K-ST5-PCS-G10</b>
Communication With EMS	LAN+CAN
Weight (kg)	<750
Dimension (W×H×D mm)	1100*2010*1000
Mounting Method	Grounded
Noise Emission (dB)	<60
Ingress Protection Rating	IP54
Overvoltage Category	III
Protective Class	I
<b>Certification</b>	
Grid Standards	NA
Safety Regulation	IEC61439-1, IEC61439-2, EN61439-1, EN61439-2, IEC60730



GoodWe Official Website

GoodWe Technologies Co., Ltd.

No. 90 Zijin Road, Suzhou High-tech Zone, China

400-998-1212

[www.goodwe.com](http://www.goodwe.com)

[service@goodwe.com](mailto:service@goodwe.com)